



# TT-600XL

60 Ton Capacity (54.4 Metric Tons)

## HYDRAULIC TRUCK CRANE

### DIMENSIONS

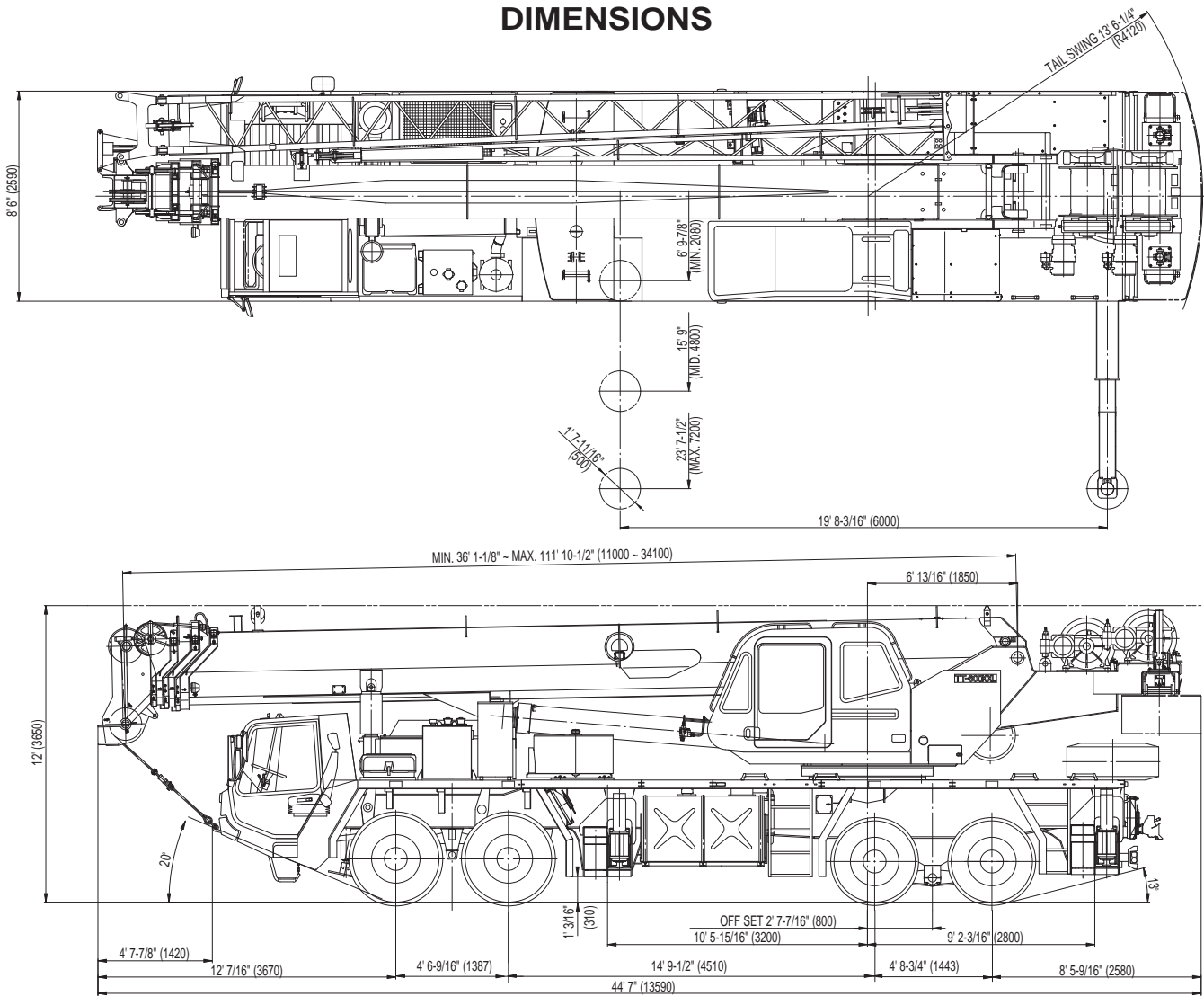

### GENERAL DIMENSIONS

Tire: 445/65R22.5(Front)  
315/80R22.5(Rear)

Turning radius	Feet	Meters
Front tire (curb to curb)	42' 8"	13.0
Over jib	49' 7"	15.1

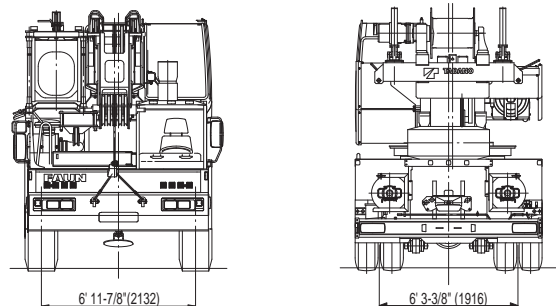

# CRANE SPECIFICATIONS

## BOOM

Four section full power synchronized telescoping boom, 36.1'~111.9' (11.0m~34.1m), of round hexagonal box construction with five sheaves, 15" (0.38m) root diameter, at boom head.

The synchronization system consists of two-telescope cylinders, an extension cable and retraction cable. Hydraulic cylinder fitted with holding valve. Two easily removable wire rope guards, rope dead end provided on both sides of boom head. Boom telescope sections are supported by wear pads both vertically and horizontally. Extension speed 75'9-3/8" in 95 seconds.

**BOOM ELEVATION** - By a double acting hydraulic cylinder with holding valve. Elevation -0.4°~80.5°, combination controls for hand or foot operation. Boom angle indicator.

Automatic speed reduction and soft stop function. Elevation speed -0.4°~80.5° in 75 seconds.

**JIB** - Two stage bi-fold lattice type with 3.5°, 25° or 45° offset (tilt type). Single sheave, 15-5/8" (0.396m) root diameter, at the head of both jib sections. Stored alongside base boom section. Jib length is 32.5' (9.9m) or 58.1' (17.7m). Assist cylinders for mounting and stowing are controlled at right side of superstructure. Self stowing jib mounting pins.

## AUXILIARY LIFTING SHEAVE (SINGLE TOP)

Single sheave, 15-5/8" (0.396m) root diameter. Mounted to main boom head for single line work (stowable).

**ANTI-TWO BLOCK** - Pendant type over-winding cut out device with audio-visual (FAILURE lamp/BUZZER) warning system.

## SWING

Hydraulic axial piston motor driven through planetary swing speed reducer. Continuous 360° full circle swing on ball bearing turntable at 1.8rpm. Equipped with manually locked/released swing brake. 360° positive swing lock. Twin swing System: Free swing or lock swing controlled by selector switch on front console. Automatic speed reduction and soft stop function.

## HOIST

**MAIN HOIST** - Variable speed type with grooved drum driven by hydraulic axial piston motor through winch speed reducer. Power load lowering and raising. Equipped with automatic brake (neutral brake) and counterbalance valve. Controlled independently of auxiliary hoist. Equipped with cable follower and drum rotation indicator.

**DRUM** - Grooved 15-3/4" (0.40m) root diameter x 22-3/4" (0.578m) wide. Wire rope: 623' of 3/4" diameter rope (190m of 19mm). Drum capacity: 1,095.5' (333.9m) 7 layers. Maximum line pull (permissible): 15,200lbs. (6,880kg)\*. Maximum line speed: 585FPM (178m/min).

**AUXILIARY HOIST** - Variable speed type with grooved drum driven by hydraulic axial piston motor through winch speed reducer. Power load lowering and raising. Equipped with automatic brake (neutral brake) and counterbalance valve. Controlled independently of main hoist. Equipped with cable follower and drum rotation indicator.

**DRUM** - Grooved 15-3/4" (0.40m) root diameter x 22-3/4" (0.578m) wide. Wire rope: 367' of 3/4" diameter rope (112m of 19mm). Drum capacity: 1,095.5' (333.9m) 7 layers. Maximum line pull (permissible): 15,200lbs. (6,880kg)\*. Maximum line speed: 585FPM (178m/min).

\* Maximum permissible line pull may be affected by wire rope strength.

**WIRE ROPE** - Warrington seal wire, extra improved plow steel, preformed, independent wire rope core, right regular lay. 3/4" (19 mm) 6X37 class

## HOOK BLOCKS

6.2 ton (5.6 metric ton) - Weighted hook with swivel and safety latch, for 3/4" (19mm) wire rope.

## HYDRAULIC SYSTEM

**PUMPS** - Two variable piston pumps for crane functions. Tandem gear pump for swing and optional equipment. Powered by carrier engine. Pump disconnect for crane is engaged/ disengaged by rocker switch from carrier cab.

**CONTROL VALVES** - Multiple valves actuated by pilot pressure with integral pressure relief valves.

**RESERVOIR** - 185 gallon (700 lit.) capacity. External sight level gauge.

**FILTRATION** - 26 micron return filter, full flow with bypass protection, located inside of hydraulic reservoir. Accessible for easy replacement.

**OIL COOLER** - Air cooled fan type.

## COUNTERWEIGHT

Hydraulically assembled/disassembled counterweight pinned to superstructure frame. 8,000lbs. (3,630kg).

## CAB AND CONTROLS

Left side, 1 man type, steel construction with sliding door access and safety glass windows opening at side. Door window is powered control. Windshield glass window and roof glass window are shatter-resistant. Adjustable control lever stands for swing, boom hoist, boom telescoping, auxiliary hoist and main hoist. Control lever stands can change neutral positions and tilt for easy access to cab. Engine throttle knob. Foot operated controls- boom hoist, boom telescoping and engine throttle. Hot water cab heater and air conditioning (OPTIONAL).

Dash-mounted engine start/stop, monitor lamps, cigarette lighter, ashtray, low noise mode switch, windshield washer and wiper switch, power window switch, swing brake switch, boom telescoping / auxiliary hoist control selector switch, main winch / auxiliary winch selector switch, swing stop cancel switch, slow elevation stop cancel switch and free swing / lock swing selector switch. Outrigger controls.

Instruments - Hydraulic oil pressure is monitored and displayed on the AML-L display panel.

Tadano electronic LOAD MOMENT INDICATOR system (AML-L) including:

- Control lever lockout function
- Lift status indicator
- Outrigger status indicator
- Warning buzzer
- Boom angle / boom length / jib offset angle / load radius / rated lifting capacities / actual loads read out
- Ratio of actual load moment to rated load moment indicator
- Automatic Speed Reduction and Soft Stop function on boom elevation and swing (swing range restricted on)
- Working condition register switch
- Load radius / boom angle / tip height / swing range preset function
- External warning lamp

TADANO AML-L monitors outrigger extended length and automatically programs the corresponding "RATED LIFTING CAPACITIES" table.

2nd boom emergency / 3rd, top boom emergency telescoping switch. Correct jib status select switch. Upper console includes working light switch, roof washer and wiper switch, oil cooler switch, emergency outrigger set up key switch and air conditioning control switch. (OPTIONAL) Swing lock lever.

NOTE: Each crane motion speed is based on unladen conditions.

## CARRIER SPECIFICATIONS

**MANUFACTURER/MODEL** - FAUN GmbH / KF70-4

**TYPE** - Left hand steering, 8x4

**FRAME** - High tensile steel, all welded mono-box construction

**TRANSMISSION** -ZF AS Tronic 12AS2301

Automatically shifting transmission system with the possibility of semi-automatic operation. 12 forward and 2 reverse speed

Gear step/Gear	Traveling speeds in mph (km/h)
1 <sup>st</sup>	0-3.91(0-6.3)
2 <sup>nd</sup>	4.97(8.0)
3 <sup>rd</sup>	6.46(10.4)
4 <sup>th</sup>	8.32(13.4)
5 <sup>th</sup>	10.50(16.9)
6 <sup>th</sup>	13.48(21.7)
7 <sup>th</sup>	17.77(28.6)
8 <sup>th</sup>	22.87(36.8)
9 <sup>th</sup>	29.45(47.4)
10 <sup>th</sup>	37.78(60.8)
11 <sup>th</sup>	47.97(77.2)
12 <sup>th</sup>	61.51(99.0)
1 <sup>st</sup> Revers	4.23(6.8)
2 <sup>nd</sup> Revers	5.41(8.7)

**AXLES** - Front: Full floating type, steering axle.

Rear: Full floating type, driving axles with inter-wheel differential lock

**STEERING** - Dual-circuit hydraulic and mechanical steering of both front axles with hydraulic power booster. Emergency steering pump mounted on 3rd axle reduction gear. Tilt telescoping steering wheel

**SUSPENSION** - Front: Load sharing type with leaf springs

Rear: Solid mounted tandem with equalizer beam and torque rod

**ENGINE** (EPA Tier 2)

Model	Cummins QSM11
No. of cylinders	6
Combustion	4 cycle, turbo charged and inter cooled
BoreXStroke, in.(mm)	4.9' X 5.8' (125X147)
Displacement, cu. in (liters)	660 (10.8)
Air inlet heater	24 volt preheat
Air cleaner	Dry type, replaceable element
Oil filter	Full flow and bypass with replaceable element
Fuel filter	Spin-on type
Fuel tank, gal.(liters)	105.6 (400), right side of carrier
Cooling	Liquid pressurized, recirculating by-pass

**BRAKE SYSTEMS** - Service: Full air brakes with multi-protective valve and auto slack adjuster on all wheels. Dual air line system internal expanding leading and trailing shoe type with Anti-lock Braking System(ABS). Parking / Emergency: Spring loaded brake on rear 4-wheels controlled by knob of spring brake valve. Auxiliary: Exhaust brake(JAKE BRAKE by Cummins)

**TIRES** - Front: 445/65R22.5 Single Rear: 315/80R22.5 Dual Spare: 445/65R22.5 SingleX'

**OUTRIGGERS** - Four hydraulic, beam and jack outriggers. Vertical jack cylinders equipped with integral holding valve. Each outrigger beam and jack is controlled independently from either side of carrier. Beams extend to 23' 7-1/2" (7.2 m) center-line and retract to within 8' 6" (2.59 m) overall width. Equipped with foldable plastic floats. Controls and sight bubble located on both side of carrier. Three outrigger extension lengths are provided with corresponding "RATED LIFTING CAPACITIES" for crane duty in confined areas

Min. extensor 6' 9-7/8" (2.08m) center to center

Mid. extensor 15' 9" (4.8m) center to center

Max. extensor 23' 7-1/2" (7.2m) center to center

Float size(Diameter) 1' 7-11/16" (0.5m)

**FRONT JACK** - A fifth hydraulically operated outrigger jack is mounted to the front carrier frame providing 360° lifting capacity. Hydraulic cylinder equipped with integral holding valve and steel float. Float size(Diameter) 1' 3-11/16" (0.4m)

**CARRIER CAB** - One man full with cab of composite structure (steel sheet metal and fiberglass), windshield of laminated safety glass with windshield wiper and washer, sliding side windows of hardened glass. Driver seat adjustable and air-suspended with headrests and 3 point safety belts. 2 rear-view mirrors (electrically adjustable), 1 wide angle mirror and additional curb mirror, all mirrors heated. Engine dependent warm-water heater with defroster nozzles for windshield and cab floor. Instrumentation includes speedometer, tachograph, rpm counter with hour meter, fuel level gauge, air pressure gauge and engine warning lamp oil pressure control lamp

Radiator	Fin and tube core, thermostat controlled
Fan, in.(mm)	Hydraulic driven fan, 29.5 (750) dia.
Starting	24 volt, 7.5 kW
Charging	24 volt system, negative ground
Battery	24 Volt DC system with 2 batteries
Compressor, air, CFM(l /min)	13.4 CFM (380) at 2,100rpm
Horsepower, hp (kW)	350 (261) at 2,100rpm
Torque, Max. ft-lb (N·m)	1,310 (1,776) at 1,400rpm
Capacity, gal.(liters)	
Cooling water	3.4 (13)
Lubrication	9.5 (36)
Engine brake	Jake brake

# STANDARD EQUIPMENT

## FOR SUPERSTRUCTURE

- Four-section full power synchronized boom 36.1'~111.9' (11.0 m~34.1 m)
- 32.5'~58.1' (9.9 m~17.7 m) two stage bi-fold lattice jib (tilt type) with 3.5°, 25° or 45° pinned offsets and self storing pins.
- Auxiliary lifting sheave (single top) stowable
- Variable speed main hoist with grooved drum, cable follower and 623' of 3/4" cable.
- Variable speed auxiliary hoist with grooved drum, cable follower and 367' of 3/4" cable.
- Drum rotation indicator (thumper type) main and auxiliary hoist
- Anti-Two block device (overwind cutout)
- Boom angle indicator
- Tadano electronic load moment indicator system (AML-L)
- Outrigger extension length detector
- Tadano twin swing system
- 360° positive swing lock
- Self centering finger control levers with pilot control
- Control pedals for boom hoist and boom telescoping
- 3 way adjustable cloth seat with armrests, high back and seat belt
- Tinted safety glass
- Front windshield wiper and washer
- Roof window wiper and washer
- Power window (Door of the cab)
- Cab floor mat
- Mirror for main and auxiliary hoists
- Cigarette lighter
- Electric fan in cab
- 6.2 ton (5.6 metric ton) hook with swivel
- Weighted hook storage compartment
- Hydraulic oil cooler
- 8,000lbs removable counterweight
- Hydraulic circuit for dolly (Elevation, swing and swing brake)
- Low noise mode
- 3 working lights
- Counterweight position indicator
- Outrigger controls and sight bubble located in superstructure cab

## FOR CARRIER

- Cummins QSM11 turbo charged and inter cooled engine with Jake brake.
- Exhaust pipe extension
- ZF Astronic semi-automatic, 12 forward and 2 reverse speeds.
- Front and spare tires:445/65R22; Rear tires:315/80R22.5
- Inter wheel differential lock
- Anti-block system (ABS)
- Towing hooks (Front and rear, Eye type)
- Carrier mounted storage box
- Trailer coupling device
- Air dryer and air cleaner dust indicator
- Either injection
- ZF - Servocom dual-circuit hydraulic steering system with emergency steering pump
- Front jack (Fifth jack)
- Aluminum fenders
- Windshield wiper and washer
- Roof hatch and sun visor
- Emergency hammer
- Speedometer, Odometer, Tachometer, Hourmeter and Tachogr
- Tilt telescoping steering wheel
- 3 way adjustable air suspension seat with 3 point type seat belt
- Windshield of laminated safety glass
- Side windows of hardened glass
- Air pressure gauge
- Engine temperature indicator
- Fuel level indicator and lockable fuel tank cap
- Gearbox display (ZF T/M indicator) and malfunction buzzer
- Front and rear fog lights
- Reversing signal (Back-up alarm)
- Electrically adjustable and heating rearview mirror
- Hazard warning system
- Electric horn
- Hot water cab heater with defroster
- FM/AM radio
- Engine over-run buzzer
- Swing brake pressure drop buzzer for dolly
- Hook block tie down front bumper
- Rotary beacon on carrier cab

## OPTIONAL EQUIPMENT

- 60 ton (54.4 metric ton) 5 sheaves hook block
- 45 ton (40.8 metric ton) 4 sheaves hook block
- Hot water cab heater and air conditioner (Upper cab)

## HOISTING PERFORMANCE

### LINE SPEEDS AND PULLS

Layer	Speed	Main or auxiliary hoist - 15-3/4" (0.4m) drum							
		Line speeds <sup>2</sup>		Line pulls					
				Available <sup>1</sup>		Permissible <sup>4</sup>			
F.P.M	m/min	Lbs.	kgf	Lbs.	kgf				
1st	High	378	115	18,200	8,260	15,200	6,880		

### DRUM WIRE ROPE CAPACITIES

Wire rope layer	Main and auxiliary drum grooved lagging			
	3/4" (19mm) wire rope			
	Rope per layer		Total wire rope	
	Feet	Meters	Feet	Meters
1	123.0	37.5	123.0	37.5

# TT-600XL WORKING RANGE CHART

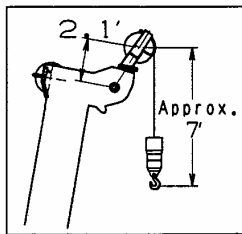
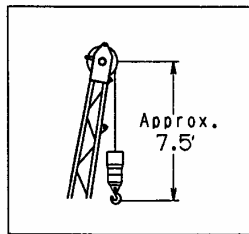
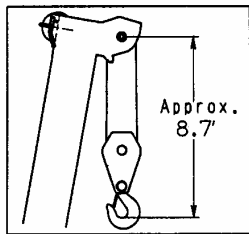
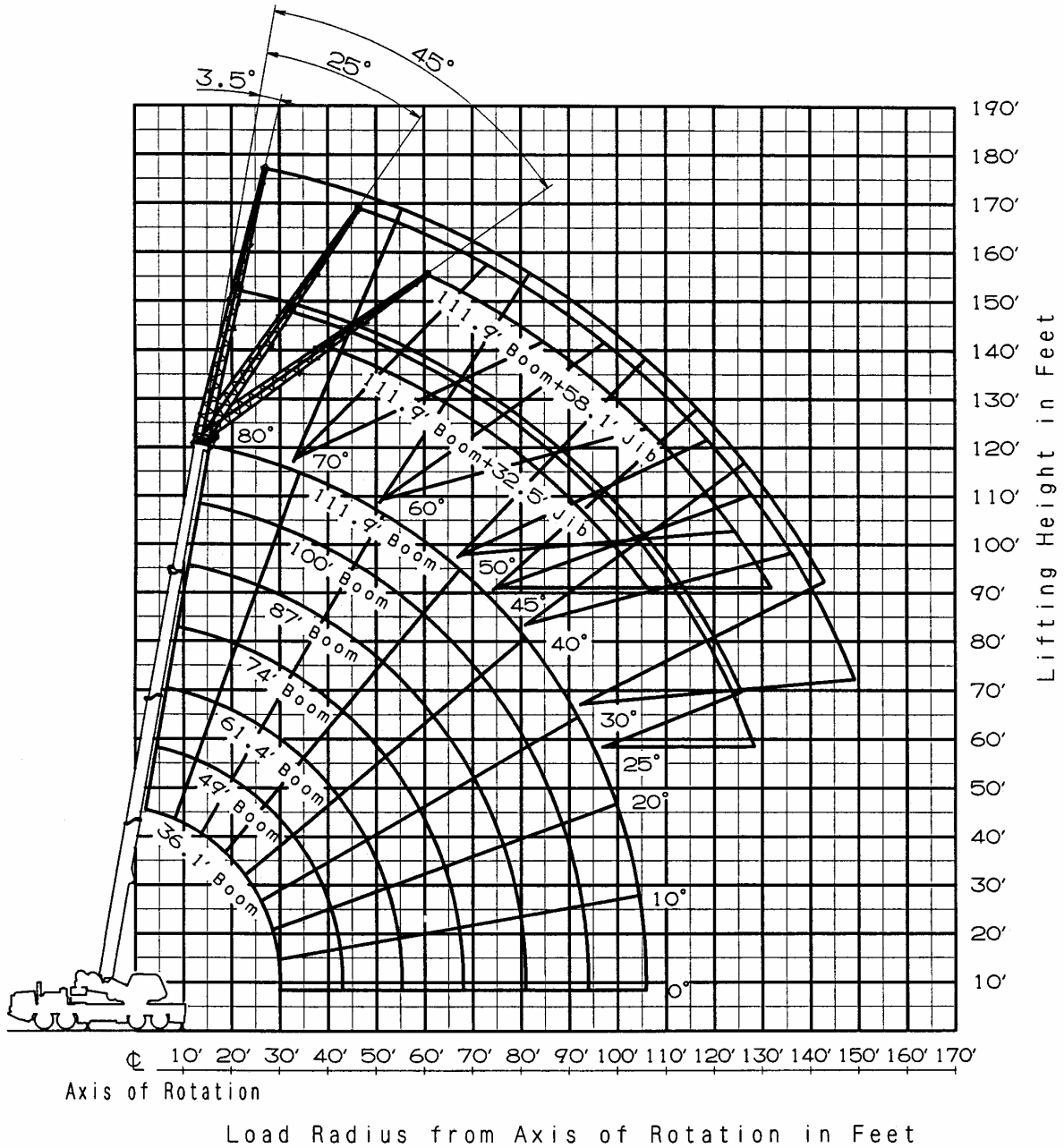

## Boom Length in Feet

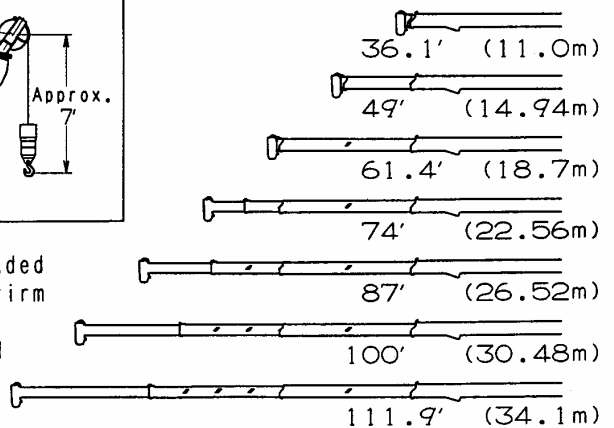

NOTE: Boom and jib geometry shown are for unloaded condition and machine standing level on firm supporting surface. Boom deflection and subsequent radius and boom angle change must be accounted for when applying load to hook.



# TT-600XL RATED LIFTING CAPACITIES (IN POUNDS)

ON OUTRIGGERS FULLY EXTENDED 23' 7-1/2" (7.2m) SPREAD, FRONT JACK EXTENDED 8,000lbs COUNTERWEIGHT, 360° ROTATION														
A B	36.1'		49'		61.4'		74'		87'		100'		111.9'	
	C	(11.0m)	C	(14.94m)	C	(18.7m)	C	(22.56m)	C	(26.52m)	C	(30.48m)	C	(34.1m)
10	67	120,000	73	90,600	77	68,300	79	40,700						
12	63	107,000	71	90,600	75	68,300	78	40,700	80	40,700				
15	57	88,200	67	90,600	72	66,200	76	40,700	78	40,700	80	37,200		
20	47	69,700	60	65,300	67	55,700	72	40,700	75	40,700	77	37,200	79	27,800
25	34	53,100	53	52,400	62	47,200	67	40,100	71	35,300	74	32,300	77	27,800
30	7	38,100	45	37,800	56	37,300	63	34,600	68	30,300	71	27,600	74	24,400
35			35	28,700	50	28,300	59	29,600	64	26,400	68	24,000	71	21,600
40			23	22,500	44	22,300	54	23,500	60	23,300	65	21,100	68	19,400
45					36	17,900	49	19,100	57	19,800	62	18,600	66	17,300
50					26	14,400	43	15,600	52	16,300	58	16,500	63	16,000
55					9	11,700	37	12,900	48	13,600	55	14,100	60	14,400
60							29	10,700	43	11,400	51	11,900	57	12,200
65							18	8,900	37	9,700	47	10,100	53	10,600
70									31	8,200	43	8,700	50	9,100
75									23	6,900	38	7,400	46	7,900
80									10	5,900	33	6,400	42	6,800
85											27	5,500	38	5,900
90											18	4,700	33	5,100
95													28	4,300
100													20	3,700
105													10	3,200
D	0°													

LIFTING CAPACITIES AT ZERO DEGREE BOOM ANGLE ON OUTRIGGERS FULLY EXTENDED 23' 7-1/2" (7.2m) SPREAD 8,000lbs COUNTERWEIGHT, 360° ROTATION, FRONT JACK EXTENDED														
A C	36.1'		49'		61.4'		74'		87'		100'		111.9'	
	B	(11.0m)	B	(14.94m)	B	(18.7m)	B	(22.56m)	B	(26.52m)	B	(30.48m)	B	(34.1m)
0	30.0	38,100	42.9	19,200	55.3	11,500	67.9	8,200	80.9	5,700	93.9	3,800	105.8	2,600

A : Boom length in feet  
B : Load radius in feet

C : Loaded boom angle (deg.)  
D : Minimum boom angle (deg.) for indicated length (no load)

- NOTE: • The lifting capacity data stored in the LOAD MOMENT INDICATOR (AML-L) is based on the standard number of parts of line listed in the chart.  
• Standard number of parts of line for each boom length should be according to the following table.

Boom Length in Feet (meters)	36.1' (11.0)	36.1' to 49' (11.0 to 14.94)	49' to 61.4' (14.94 to 18.7)	61.4' to 111.9' (18.7 to 34.1)	Single top Jib
Number of parts of line	10	8	6	4	1

ON OUTRIGGERS FULLY EXTENDED 23' 7-1/2" (7.2m) SPREAD, FRONT JACK EXTENDED 8,000lbs COUNTERWEIGHT, 360° ROTATION												
C	111.9' (34.1m) Boom + 32.5' (9.9m) Jib						111.9' (34.1m) Boom + 58.1' (17.7m) Jib					
	3.5° offset		25° offset		45° offset		3.5° offset		25° offset		45° offset	
	R	W	R	W	R	W	R	W	R	W	R	W
80°	25.0	12,300	37.3	11,000	44.8	8,400	32.6	7,900	53.4	6,000	66.3	4,400
75°	38.9	12,300	50.1	10,200	56.7	8,200	49.4	7,900	67.9	5,300	79.0	4,100
70°	51.9	11,800	62.1	8,700	67.2	7,300	64.6	7,200	81.9	4,800	90.8	3,900
65°	63.5	9,600	73.2	7,700	76.6	6,700	78.1	6,300	94.8	4,400	101.0	3,700
60°	74.5	8,000	84.1	6,800	86.4	6,100	90.9	5,300	107.0	3,900	111.0	3,400
55°	84.7	6,900	93.7	6,000	95.1	5,600	103.0	4,600	118.0	3,600	120.0	3,200
50°	93.9	5,400	102.0	4,900	103.0	4,700	113.0	3,700	127.0	3,200	128.0	3,000
45°	102.0	4,200	110.0	3,900	110.0	3,800	123.0	2,800	136.0	2,500	136.0	2,400
40°	110.0	3,300	117.0	3,100			132.0	2,100	143.0	1,900		
35°	117.0	2,700	123.0	2,500			140.0	1,600	149.0	1,400		
30°	123.0	2,100	128.0	2,100			147.0	1,200	154.0	1,100		
25°	129.0	1,700	132.0	1,700								

C : Loaded boom angle (deg.)  
R : Load radius in feet  
W : Rated lifting capacity in pounds

# TT-600XL RATED LIFTING CAPACITIES (IN POUNDS)

ON OUTRIGGERS MID EXTENDED 15' 9" (4.8m) SPREAD, FRONT JACK EXTENDED 8,000lbs COUNTERWEIGHT, 360° ROTATION														
A B	36.1'		49'		61.4'		74'		87'		100'		111.9'	
	C	(11.0m)	C	(14.94m)	C	(18.7m)	C	(22.56m)	C	(26.52m)	C	(30.48m)	C	(34.1m)
10	67	109,400	73	90,600	77	68,300	79	40,700						
12	63	93,000	71	90,600	75	68,300	78	40,700	80	40,700				
15	57	74,900	67	74,800	72	66,200	76	40,700	78	40,700	80	37,200		
20	47	41,300	60	40,400	67	39,800	72	40,700	75	40,700	77	37,200	79	27,800
25	34	26,500	53	26,100	62	25,600	67	27,000	71	27,900	74	28,500	77	27,800
30	8	18,300	45	18,100	56	17,700	63	19,100	68	19,800	71	20,400	74	20,800
35			35	12,600	50	12,200	58	13,600	64	14,400	68	15,000	71	15,400
40			22	8,800	43	8,600	53	9,900	60	10,700	65	11,200	68	11,600
45					35	6,000	48	7,300	56	8,000	61	8,500	65	8,900
50					25	4,000	43	5,300	52	6,000	58	6,500	62	6,900
55					8	2,500	36	3,700	47	4,500	54	5,000	59	5,300
60							29	2,400	43	3,200	51	3,800	56	4,100
65							18	1,400	37	2,200	47	2,700	53	3,100
70									31	1,300	42	1,900	49	2,200
75													45	1,500
D	0°							31°		42°		45°		

LIFTING CAPACITIES AT ZERO DEGREE BOOM ANGLE ON OUTRIGGERS MID EXTENDED 15' 9" (4.8m) SPREAD 8,000lbs COUNTERWEIGHT, 360° ROTATION, FRONT JACK EXTENDED														
A C	36.1'		49'		61.4'		74'							
	B	(11.0m)	B	(14.94m)	B	(18.7m)	B	(22.56m)						
0	30.0	18,300	42.9	6,800	55.3	2,400	67.9	900						

A :Boom length in feet

C :Loaded boom angle (deg.)

B :Load radius in feet

D :Minimum boom angle (deg.) for indicated length (no load)

NOTE: • The lifting capacity data stored in the LOAD MOMENT INDICATOR (AML-L) is based on the standard number of parts of line listed in the chart.

• Standard number of parts of line for each boom length should be according to the following table.

Boom Length in Feet (meters)	36.1' (11.0)	36.1' to 49' (11.0 to 14.94)	49' to 61.4' (14.94 to 18.7)	61.4' to 111.9' (18.7 to 34.1)	Single top Jib
Number of parts of line	10	8	6	4	1

ON OUTRIGGERS MID EXTENDED 15' 9" (4.8m) SPREAD, FRONT JACK EXTENDED 8,000lbs COUNTERWEIGHT, 360° ROTATION													
C	111.9' (34.1m) Boom + 32.5' (9.9m) Jib						111.9' (34.1m) Boom + 58.1' (17.7m) Jib						
	3.5° offset		25° offset		45° offset		3.5° offset		25° offset		45° offset		
	R	W	R	W	R	W	R	W	R	W	R	W	
80°	25.3	12,300	37.5	11,000	44.8	8,400	32.8	7,900	53.1	6,000	66.3	4,400	
75°	39.2	12,300	50.2	10,200	56.2	8,200	49.4	7,900	67.9	5,300	79.0	4,100	
70°	50.5	8,200	61.0	6,400	65.8	5,600	62.7	5,400	81.2	3,900	90.3	3,200	
65°	61.3	4,800	71.5	4,000	75.5	3,600	75.2	3,000	93.1	2,300	100.0	1,900	
60°	72.0	2,800	81.6	2,300	84.4	2,100	87.3	1,500	104.0	1,100			
55°	81.9	1,400	91.1	1,200	93.2	1,100							

C :Loaded boom angle (deg.)

R :Load radius in feet

W :Rated lifting capacity in pounds





# TT-600XL RATED LIFTING CAPACITIES (IN POUNDS)

ON OUTRIGGERS MID EXTENDED 15' 9" (4.8m) SPREAD, FRONT JACK EXTENDED 0 lbs COUNTERWEIGHT, 360° ROTATION														
A \ B	36.1'		49'		61.4'		74'		87'		100'		111.9'	
	C	(11.0m)	C	(14.94m)	C	(18.7m)	C	(22.56m)	C	(26.52m)	C	(30.48m)	C	(34.1m)
10	67	104,700	73	90,600	77	68,300	79	40,700						
12	63	88,600	71	88,400	75	68,300	78	40,700	80	40,700				
15	57	59,200	67	57,800	72	57,000	76	40,700	78	40,700	80	37,200		
20	47	31,100	60	30,200	67	29,700	72	31,300	75	32,300	77	33,100	79	27,800
25	34	18,600	53	17,800	62	17,300	67	19,000	71	20,000	74	20,800	77	21,300
30	8	11,300	45	11,000	56	10,500	63	12,000	68	12,900	71	13,600	74	14,000
35			35	6,900	50	6,500	58	7,900	64	8,700	68	9,300	71	9,700
40			22	4,100	43	3,900	53	5,100	60	5,900	65	6,500	68	6,900
45							48	3,200	56	3,900	61	4,500	65	4,800
50							43	1,700	52	2,500	58	3,000	62	3,300
55									47	1,300	54	1,800	59	2,200
D	0°				43°				47°		54°		59°	

LIFTING CAPACITIES AT ZERO DEGREE BOOM ANGLE ON OUTRIGGERS MID EXTENDED 15' 9" (4.8m) SPREAD 0 lbs COUNTERWEIGHT, 360° ROTATION, FRONT JACK EXTENDED														
A \ C	36.1'		49'		61.4'		74'		87'		100'		111.9'	
	B	(11.0m)	B	(14.94m)										
0	30.0	11,300	42.9	2,400										

A : Boom length in feet

C : Loaded boom angle (deg.)

B : Load radius in feet

D : Minimum boom angle (deg.) for indicated length (no load)

NOTE: • The lifting capacity data stored in the LOAD MOMENT INDICATOR (AML-L) is based on the standard number of parts of line listed in the chart.

• Standard number of parts of line for each boom length should be according to the following table.

Boom Length in Feet (meters)	36.1' (11.0)	36.1' to 49' (11.0 to 14.94)	49' to 61.4' (14.94 to 18.7)	61.4' to 111.9' (18.7 to 34.1)	Single top Jib
Number of parts of line	10	8	6	4	1

# TT-600XL RATED LIFTING CAPACITIES (IN POUNDS)

ON OUTRIGGERS MIN EXTENDED 6' 9-7/8" (2.08m) SPREAD, FRONT JACK EXTENDED 360° ROTATION				
Load Radius in Feet	36.1' (11.0m) Boom			
	Counterweight in pounds			
	8,000		0	
	C		C	
10	67	41,400	67	27,000
12	63	29,700	63	18,700
15	57	19,600	57	11,400
20	47	10,800	47	5,000
25	34	6,000		
30	7	3,100		
D	0°		47° / 0° *	

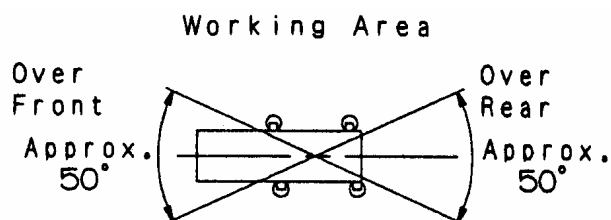

C: Loaded boom angle (deg.)

D: Minimum boom angle (deg.) for indicated length (no load)

\*: When Working Area is only Over Front and Over Rear.

LIFTING CAPACITIES AT ZERO DEGREE BOOM ANGLE ON OUTRIGGERS MIN EXTENDED 6' 9-7/8" (2.08m) SPREAD, FRONT JACK EXTENDED				
Boom Angle	360° Rotation		Over Front and Over Rear	
	36.1' (11.0m) Boom			
	Counterweight in pounds			
	8,000		0	
	B		B	
0	30.0	3,100	20.0	5,000

**B** :Load radius in feet

NOTE: • The lifting capacity data stored in the LOAD MOMENT INDICATOR (AML-L) is based on the standard number of parts of line listed in the chart.

• Standard number of parts of line for each boom length should be according to the following table.

Boom Length in Feet (meters)	36.1' (11.0)
Number of parts of line	10

# WARNING AND OPERATING INSTRUCTIONS FOR LIFTING CAPACITIES

## GENERAL

1. RATED LIFTING CAPACITIES apply only to the machine as originally manufactured and normally equipped by TADAN LTD.  
Modifications to the machine or use of optional equipment other than that specified can result in a reduction of capacity.
2. Construction equipment can be hazardous if improperly operated or maintained. Operation and maintenance of the machine must be in compliance with information in the operation, safety and maintenance manual supplied with the machine. If these manuals are missing, order replacements through the distributor.
3. The operator and other personnel associated with the machine shall fully acquaint themselves with the latest American National Standards Institute (ANSI) safety standards for cranes.

## SET UP

1. Rated lifting capacities on the chart are the maximum allowable crane capacities and are based on the machine standing level on firm supporting surface under ideal job conditions. Depending on the nature of the supporting surface, it may be necessary to have structural support under the outrigger floats to spread the loads to a large bearing surface.
2. For outrigger operation, outriggers shall be properly extended with tires free of supporting surface before operating crane. The front jack must be properly extended.

## OPERATION

1. Rated lifting capacities have been tested to and meet minimum requirements of SAE J1063-Cantilevered Boom Crane Structures Method of Test.
2. Rated lifting capacities do not exceed 85% of the tipping load on outriggers fully extended as determined by SAE J765-Crane Stability Test Code.  
Rated lifting capacities for partially extended outriggers are determined from the formula, Rated Lifting Capacity = (Tipping Load - 0.1 x Tip Reaction) / 1.25.
3. Rated lifting capacities above bold lines in the chart are based on crane strength and those below, on its stability. They are based on actual load radius increased by boom deflection.
4. The weight of handling device such as hook blocks, sling, etc., must be considered as part of the load and must be deducted from the lifting capacities.
5. Rated lifting capacities are based on freely suspended loads and make no allowance for such factors as the effect of wind, sudden stopping of loads, supporting surface condition, operating speeds, side loads, etc. Side pull on boom or jib is extremely dangerous.
6. Rated lifting capacities do not account for wind on lifted load or boom. Rated lifting capacities and boom length shall be appropriately reduced, when wind velocity is above 20 mph (9 m/sec.).
7. Rated lifting capacities at load radius shall not be exceeded. Do not tip the crane to determine allowable load.
8. Do not operate at boom lengths, radii, or boom angle, where no capacities are shown. Crane may overturn without a load on the hook.
9. When boom length is between values listed, refer to the rated lifting capacities of the next longer and next shorter booms for the same radius. The lesser of the two rated lifting capacities shall be used.

10. When making lifts at a load radius not shown, use the next longer radius to determine allowable capacity.
11. Load per line should not exceed 12,300 lbs. (5,600kg) for main winch and auxiliary winch.
12. Check the actual number of parts of line with LOAD MOMENT INDICATOR (AML-L) before operation. Maximum lifting capacity is restricted by the number of parts of line of LOAD MOMENT INDICATOR (AML-L). Limited capacity is as determined from the formula, Single line pull for main winch (12,300 lbs.) x number of parts of line.
13. The boom angle before loading should be greater to account for deflection. For rated lifting capacities, the loaded boom angle and the load radius is for reference only.
14. The 36.1' (11.0m) boom length capacities are based on boom fully retracted. If not fully retracted [less than 49' (14.94m) boom length], use the rated lifting capacities for the 49' (14.94m) boom length.
15. Extension or retraction of the boom with loads may not be attempted within the limits of the RATED LIFTING CAPACITIES. The ability to telescope loads is limited by hydraulic pressure, boom angle, boom length, crane maintenance, etc.
16. For lifting capacity of single top, reduce the rated lifting capacities of relevant boom according to a weight reduction for auxiliary load handling equipment. Capacities of single top shall not exceed 12,300 lbs. (5,600kg) including main hook.
17. When base jib or top jib or both jib removing, jib state switch select removed.
18. When erecting and stowing jib, be sure to retain it by hand or by other means to prevent its free movement.
19. Use "ANTI-TWO BLOCK" disable switch when erecting and stowing jib and when stowing hook block. While the switch is pushed, the hoist does not stop, even when overwind condition occurs.
20. For boom length with 32.5' (9.9m) jib, rated lifting capacities are determined by loaded boom angle only in the column headed "111.9' (34.1m) boom + 32.5' (9.9m) jib".  
For boom length with 58.1' (17.7 m) jib, rated lifting capacities are determined by loaded boom angle only in the column headed "111.9' (34.1m) boom + 58.1' (17.7m) jib".  
For angles not shown, use the next lower loaded boom angle to determine allowable capacity.
21. When lifting a load by using jib (aux. winch) and boom (main winch) simultaneously, do the following:
  - Enter the operation status as jib operation, not as boom operation.
  - Before starting operation, make sure that mass of load is within rated lifting capacity for jib.

## DEFINITIONS

1. Load Radius: Horizontal distance from a projection of the axis of rotation to supporting surface before loading to the center of the vertical hoist line or tackle with load applied.
2. Loaded Boom Angle: The angle between the boom base section and the horizontal, after lifting the rated lifting capacity at the load radius.
3. Working Area: Area measured in a circular arc about the centerline of rotation.
4. Freely Suspended Load: Load hanging free with no direct external force applied except by the hoist line.
5. Side Load: Horizontal side force applied to the lifted load either on the ground or in the air.

# WARNING AND OPERATING INSTRUCTIONS FOR USING THE LOAD MOMENT INDICATOR (AML-L)

1. When operating crane on outriggers:
  - Set Starter switch to "ON" position.
  - Press the outrigger mode select key to register for the outrigger operation. Press the register key, then the outrigger mode indicative symbol changes from flashing to a solid light.
  - Press the lift mode select key to select the lift status that corresponds to the actual boom configuration. Each time the lift mode select key is pressed, the status changes. Press the register key to register the lift status, then the lift indicative symbol changes from flashing to a solid light.
  - When mounting and stowing jib, select the jib set status. (The jib lift indicative symbol will be flashing.)
2. A swing does not automatically stop even if the crane becomes overloaded.
3. During crane operation, make sure that the displays on front panel of the LOAD MOMENT INDICATOR (AML-L) are in accordance with actual operating conditions.
4. The displayed values of LOAD MOMENT INDICATOR (AML-L) are based on freely suspended loads and make no allowance for such factors as the effect of wind, sudden stopping of loads, supporting surface conditions, operating speed, side loads, etc. For safe operation, it is recommended when extending and lowering boom or swinging, lifting loads shall be appropriately reduced.
5. LOAD MOMENT INDICATOR (AML-L) is intended as an aid to the operator. Under no condition should it be relied upon to replace use of capacity charts and operating instruction. Sole reliance upon LOAD MOMENT INDICATOR (AML-L) aids in place of good operating practice can cause an accident. The operator must exercise caution to assure safety.

## TT-600XL Axle weight distribution chart

	Pounds			Kilograms		
	GVW	Front	Rear	GVW	Front	Rear
Base machine with 105.7gal.(400L) fuel and spare tire, no counterweight.	81,790	36,005	45,785	37,100	16,334	20,766
Remove:						
1. Auxiliary hoist with 367' (112m) of 3/4" (19mm)	-1,910	610	-2,520	-865	278	-1,143
2. 6.2 ton (5.6 metric ton) hook ball	-290	-340	50	-132	-154	22
3. Top jib (25.6')	-670	-400	-270	-306	-184	-122
4. Base jib (32.5')	-1,920	-2,020	100	-872	-919	47
5. Spare tire	-360	140	-500	-165	62	-227
6. Auxiliary lifting sheave	-110	-185	75	-50	-84	34
Add:						
1. Counterweight 8,000lbs on upper	8,000	-3,780	11,780	3,630	-1,715	5,345
2. Counterweight 8,000lbs to carrier deck	8,000	5,950	2,050	3,630	2,697	933
Options:						
1. 60 ton(54.5 metric ton) hook block tied on front bumper	1,049	1,556	-507	476	706	-230
2. 60 ton(54.5 metric ton) hook block on carrier deck	1,049	609	440	476	276	200
3. 45 ton(40.8 metric ton) hook block tied on front bumper	760	1,124	-364	345	510	-165
4. 45 ton(40.8 metric ton) hook block on carrier deck	760	440	320	345	200	145
5. Hot water cab heater and air conditioning in upper cab	210	20	190	97	9	88

## Permissible Axle Load

	Pounds			Kilograms		
	GVW	Front	Rear	GVW	Front	Rear
Permissible axle load	105,800	48,500	57,300	48,000	22,000	26,000

