

TADANO

TR-400E

45 Ton Capacity (40.0 metric tons)

HYDRAULIC ROUGH-TERRAIN CRANE

DIMENSIONS

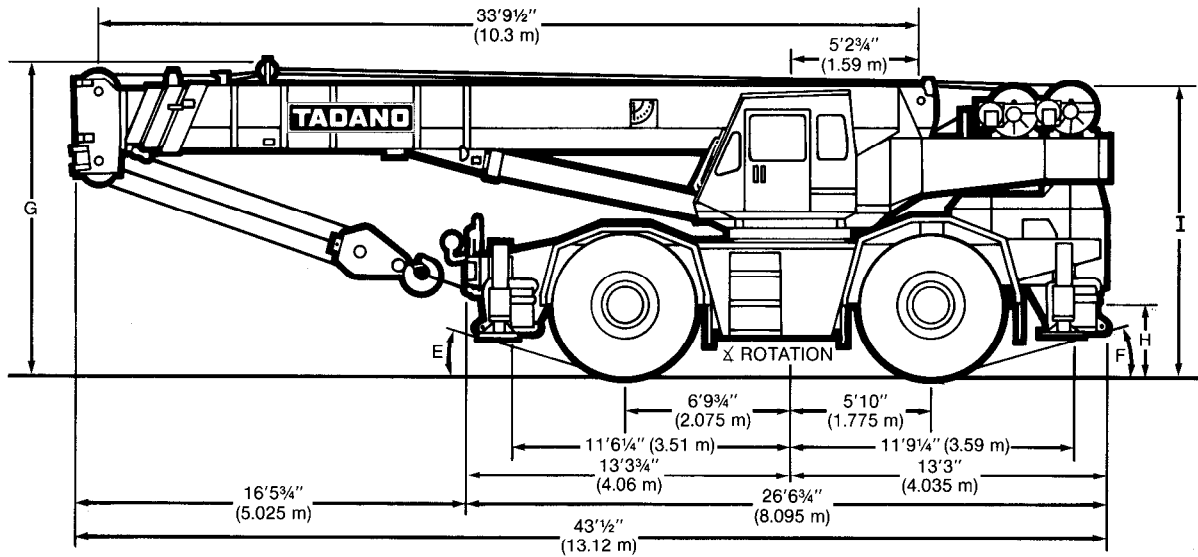

GENERAL DIMENSIONS

	Feet	Meters
Turning Radius:		
4 wheel steer	21'3 7/8"	(6.5 m)
2 wheel steer	37'8 3/4"	(11.5 m)
Tail swing of counterweight	13'1 1/2"	(4.0 m)

DIMENSIONS AFFECTED BY TIRES

Tires	21.00 x 25	26.5 x 25
A	8'4 7/8" (2.562 m)	8'2 1/2" (2.502 m)
B	10'10 1/2" (3.315 m)	10'10 1/2" (3.315 m)
C	1'5 9/16" (0.440 m)	1'6 1/8" (0.46 m)
D	5 1/16" (0.147 m)	5 1/8" (0.13 m)
E	15.3°	16.0°
F	12.4°	12.9°
G	12'3 3/8" (3.75 m)	12'4 7/16" (3.77 m)
H	2'7 3/16" (0.792 m)	2'7 7/8" (0.81 m)
I	11'9 3/4" (3.60 m)	11'10 1/2" (3.62 m)

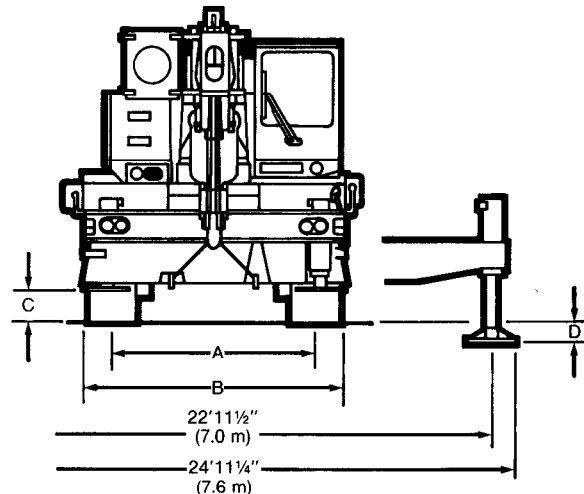

Note: Dimension G is with boom angle at -1°.

Crane Specifications

BOOM

TADANO originally designed 33.8' ~ 106.6' (10.3 m ~ 32.5 m) four section full power synchronized telescoping boom of hexagonal box construction with four sheaves, 17 $\frac{1}{4}$ " (0.438 m) root diameter, at boom head. Two easily removable wire rope guards, rope dead end provided on right side of boom head. Boom telescope sections are supported by wear pads both vertically and horizontally.

Boom elevation — Two double acting hydraulic cylinders with holding valve. Elevation -3°~80°, combination controls for hand or foot operation. Boom angle indicator.

Jib — Box type top section telescopes from lattice type base section which stores alongside base boom section. 5° or 30° offset (tilt type). Single sheave, 17 $\frac{1}{4}$ " (0.438 m) root diameter, at jib head. Jib length is 32.2' (9.8 m) or 56.1' (17.1 m).

Auxiliary Lifting Sheave (Single top) — Optional. Single sheave, 17 $\frac{1}{4}$ " (0.438 m) root diameter. Mounted to main boom head for single line work. (Stowable.)

Anti-Two Block — Pendant type over-winding cut out device with audio-visual (FAILURE lamp/BUZZER) warning system.

SWING

Hydraulic axial piston motor driven through planetary swing speed reducer. Continuous 360° full circle swing on ball bearing turntable at 2.2 rpm. Equipped with manually locked/released swing brake. A swing lock (pin-in-hole lock) for pick and carry and travel modes, manually engaged in cab.

HOIST

Main hoist — Variable speed type with grooved drum driven by hydraulic axial piston motor through winch speed reducer. Power load lowering and raising. Equipped with automatic brake (neutral brake) and counterbalance valve. Controlled independently of auxiliary hoist.

Drum — Grooved 15 $\frac{3}{4}$ " (0.400 m) root diameter x 22 $\frac{3}{4}$ " (0.578 m) wide. Wire rope: 574 ft. of $\frac{3}{4}$ " diameter rope (175 m of 19 mm). Drum capacity: 905 ft. (276 m) 6 layers. Maximum line pull (permissible): 14,272 lbs. (6474 kgs)*. Maximum line speed: 525 FPM (160 m/min).

Auxiliary hoist — Variable speed type with grooved drum driven by hydraulic axial piston motor through winch speed reducer. Power load lowering and raising. Equipped with automatic brake (neutral brake) and counterbalance valve. Controlled independently of main hoist.

Drum — Grooved 15 $\frac{3}{4}$ " (0.400 m) root diameter x 22 $\frac{3}{4}$ " (0.578 m) wide. Wire rope: 361 ft. of $\frac{3}{4}$ " diameter rope (110 m of 19 mm). Drum capacity: 905 ft. (276 m) 6 layers. Maximum line pull (permissible): 14,272 lbs. (6474 kgs)*. Maximum line speed: 525 FPM (160 m/min).

Wire rope — Filler wire, extra improved plow steel, preformed, independent wire rope core, right regular lay.
3/4" (19 mm) 6 x 37 class
3/4" (19 mm) 19 x 7 class

19 x 7 is non-spin rope intended for single line work and is not recommended for multiple part reeving.

Hook blocks — Optional

1. 45 Ton (40 metric tons) — 4 sheaves with swivel hook and safety latch, for $\frac{3}{4}$ " (19 mm) wire rope.
2. 22 Ton (20 metric tons) — 2 sheaves with swivel hook and safety latch, for $\frac{3}{4}$ " (19 mm) wire rope. Optional.
3. 5.5 Ton (5.0 metric tons) — Weighted hook with swivel and safety latch, for $\frac{3}{4}$ " (19 mm) wire rope.

HYDRAULIC SYSTEM

Pumps — Two variable piston pumps and one gear pump for crane. Tandem gear pump for steering and optional equipment. Powered by carrier engine. Pump disconnect for crane is engaged/disengaged by rotary switch from operator's cab.

Control valves — Multiple valves actuated by hand levers with integral pressure relief valves.

Reservoir — 195 gallon (740 lit.) capacity. External sight level gauge.

Filtration — 26 micron return line filter, located inside of hydraulic reservoir. Accessible for easy replacement.

Oil Cooler — Air cooled fan type.

CAB AND CONTROLS

Both crane and drive operations can be performed from one cab mounted on rotating superstructure, reducing vibration with rubber mounts.

Left side, 1 man type, steel construction with sliding door access and safety glass windows opening at side and roof. Windshield glass is shatter-resistant. Adjustable-control levers for swing, boom telescope, boom hoist, auxiliary hoist and main hoist (with swing free-lock selector switch). Engine throttle lever. Foot operated controls: boom hoist, service brake and engine throttle.

Dash-mounted engine start/stop, monitor lamps, electronic working condition indicator with boom length/angle, radius/hook height and rated loads/actual loads indication, telescoping correction switches, pump engaged/disengaged switch, working condition indicator select switch, cigarette lighter, windshield wiper switch, engine cut-off switch, drum rotation indicator.

Operator's right hand console includes transmission gear selector, high/low range selector, outrigger controls, sight level bubble, steering mode select switch, working light switch, swing lock lever, ashtray and parking brake selector.

Swing brake and reclining seat with high back (with seat belt).

Instruments — Engine water temperature, air pressure, fuel, speedometer, hydraulic oil pressure, torque converter oil pressure, torque converter temperature, tachometer and hourmeter.

*Maximum permissible line pull may be affected by wire rope strength.

Carrier Specifications

Type — Rear engine, left hand steering, driving axle 2-way selected type by manual switch. 4 x 2 front drive, 4 x 4 front and rear drive.

Frame — High-tensile steel, all welded mono-box construction.

Transmission — Torque converter driving full powershift with driving axle selector. 6 forward and 6 reverse speeds.

Travel Speed — 21.8 mph maximum.

Axle — *Front*: Ridged mounted, steering and driving axle with planetary reduction. *Rear*: Pivot mounted, steering and driving axle with planetary reduction. No-spin differential.

Steering — Hydraulic power steering controlled by steering wheel. Three steering modes available: 2 wheel front, 4 wheel coordinated, and 4 wheel crab.

Suspension — *Front*: Rigid mounted to the frame. *Rear*: Pivot mounted with hydraulic lockout cylinders.

Brake Systems — *Service*: Air over hydraulic brakes on all four wheels. *Parking/emergency*: Spring operated air released brake acting on input shaft of front axle.

Tires — *Front*: Standard 21.00 x 25 — 24 PR (OR), optional 26.50 x 25 — 24 PR (OR)
Rear: Standard 21.00 x 25 — 24 PR (OR), optional 26.50 x 25 — 24 PR (OR)

Outriggers — Four hydraulic, beam and jack outriggers. Vertical jack cylinders equipped with integral holding valve. Beams extend to 22'11½" (7.0 m) centerline-to-centerline and retract to within 10'10½" (3.315 m) overall width with floats. Outrigger jack floats are attached thus eliminating the need of manually attaching and detaching them. Controls and sight level bubble located in upperstructure cab.

ENGINE

Model	MITSUBISHI 6D22	Radiator	Fin and tube core, thermostat controlled
Type	Direct Injection Diesel	Fan, in. (mm)	6 blade, blower type, 25.6 (650) dia.
No. of cylinders	6	Starting	24 volt motor
Combustion	4 cycle, naturally aspirated	Charging	24 volt system, negative ground
Bore x stroke, in. (mm)	5.118 x 5.512 (130 x 140)	Battery	2 — 140 amp. hour
Displacement, cu. in. (liters)	680 (11.149)	Compressor, air, CFM (LPM)	14.9 CFM (420 LPM) at 2,000 rpm
Air inlet heater	24 volt preheat	Horsepower, HP (KW)	Gross 190 (139) at 2300 rpm Net 180 (134) at 2300 rpm
Air cleaner	Dry type, replacement element	Torque, Max., ft.-lb. (kgm)	463 (64) at 1400 rpm
Oil filter	Fullflow with replacement element	Capacity, gal. (liters)	
Fuel filter	Fullflow with replacement element	Fuel	79.2 (300)
Fuel tank, gal. (liters)	79.2 (300), right side of carrier	Cooling water	5.8 (22)
Cooling	Liquid pressurized, recirculating by-pass	Lubrication	6.3 ~ 7.7 (24 ~ 29)

AXLE WEIGHT DISTRIBUTION CHART

ITEM	POUNDS			KILOGRAMS		
	G.V.W.	FRONT	REAR	G.V.W.	FRONT	REAR
Basic standard machine to include: 33.8' ~ 106.6' (10.3 m ~ 32.5 m) 4 section boom; 32.2' ~ 56.1' (9.8 m ~ 17.1 m) 2-stage jib; main hoist with 574' (175 m) of ¾" (19 mm) diameter rope; aux. hoist with 361' (110 m) of ¾" (19 mm) diameter rope; 45 ton (40 metric ton) hookblock; 5.5 ton (5 metric ton) hookball; Mitsubishi 6D22 engine; 21.00 x 25-24 PR tires.	85,668	43,911	41,757	38,859	19,918	18,941
ADD: Auxiliary lifting sheave (single top)	+132	+361	-229	+60	+164	-104
SUBSTITUTE: 26.50 x 25-24 PR tires 29.50 x 25-22 PR tires	+970 +1,480	+485 +740	+485 +740	+440 +672	+220 +336	+220 +336
REMOVE: 32.0' ~ 56.0' (9.8 m ~ 17.1 m) 2-stage jib 45 ton (40 metric ton) hookblock 5.5 ton (5 metric ton) hookblock	-2,220 -1,000 -330	-3,260 -1,776 +112	+1,060 +776 -442	-1,000 -455 -150	-1,480 -807 +51	+480 +352 -201

Standard Equipment

- Four section full power synchronized boom 33.8' – 106.7' (10.3 m – 32.5 m)
- Two stage stowable telescoping jib 32.2' (9.8 m) or 56.1' (17.1 m) with 5° or 30° pinned offset (tilt type)
- Variable speed main hoist driven by axial piston motor with drum rotation indicator and cable
- Variable speed auxiliary hoist driven by axial piston motor with drum rotation indicator and cable
- Boom hoist foot control
- Boom angle indicator
- Tadano twin swing system
- 4 x 4 x 4 drive
- Hydraulic lock out system on rear axle
- Independently controlled outriggers
- Self-storing outrigger pads
- Full powershift transmission driven by torque converter
- Complete highway light package
- Anti two block device (Overwind cutout)
- Front windshield wiper and washer
- Roof windshield wiper
- Rear view mirrors (right and left side)
- Seat belt
- Back up alarm
- Low oil pressure/High water temperature warning device (visual)
- Rear steer centering light
- Fenders
- Air cleaner dust indicator
- Towing hooks — front and rear
- Lifting eyes
- Tool storage compartment
- Electronic crane monitoring system
- Electronic working condition indicator system including:
 - Load weight indicator – rated and actual
 - Boom length indicator
 - Boom angle indicator
 - Load radius indicator
 - Hook height indicator
- Full instrumentation package
- Pump disconnect in operator's cab
- Air dryer
- Hydraulic oil cooler
- Non-spin rear differential
- Flood lights
- Cable follower
- Outrigger hose protection
- 24 volt start

Optional Equipment

- Auxiliary lifting sheave (single top) stowable
- 45 ton (40 metric ton) 4 sheave hook block
- 5.5 ton (5 metric ton) hook ball and swivel
- Heater
- Optional tires
- Fire extinguisher

Hoisting Specifications

LINE SPEEDS AND PULLS

Layer	Speed	Main or auxiliary hoist — 15¾" (0.4 m) drum					
		Line speeds ②		Line pulls			
		F.P.M.	m/min.	Available ①		Permissible ①	
				Lbs.	kgfs	Lbs.	kgfs
1st	Low	180	55	15698	7121	14272	6474
	High	361	110				
2nd	Low	197	60	14647	6644	13315	6040
	High	394	120				
3rd	Low	213	65	13520	6133	12292	5576
	High	427	130				
4th	Low	230	70	12557	5696	11417	5179
	High	460	140				
5th	Low	246	75	11721	5317	10657	4834
	High	492	150				
6th ③	Low	262	80	10989	4985	9991	4532
	High	525	160				

① Developed by machinery with first layer of wire rope, but not based on rope strength or other limitation in machinery or equipment.
 ② Line speeds based on only hook block, not loaded.

DRUM WIRE ROPE CAPACITIES

Wire rope layer	Main and auxiliary drum grooved lagging			
	¾" (19 mm) wire rope			
	Rope per layer		Total wire rope	
	Feet	Meters	Feet	Meters
1	123.0	37.5	123.0	37.5
2	134.2	40.9	257.2	78.4
3	145.3	44.3	402.5	122.7
4	156.5	47.7	559.0	170.4
5	167.7	51.1	726.7	221.5
6	178.8	54.5	905.5	276.0

DRUM DIMENSIONS

	Inch	mm
Root diameter	15¾"	400
Length	22¾"	578
Flange diameter	25½"	645

③ Sixth layer of wire rope is not recommended for hoisting operations.
 ④ Permissible line pull may be affected by wire rope strength.

Working Radius — Lifting Height Diagram

BOOM

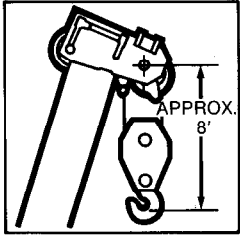

JIB

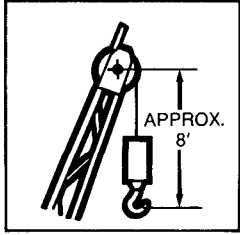

SINGLE TOP

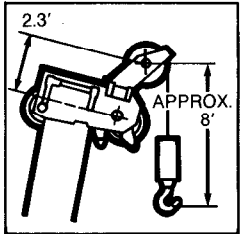

NOTE: Boom and jib geometry shown are for unloaded condition and machine standing level on firm supporting surface. Boom deflection and subsequent radius and boom angle change must be accounted for when applying load to hook.

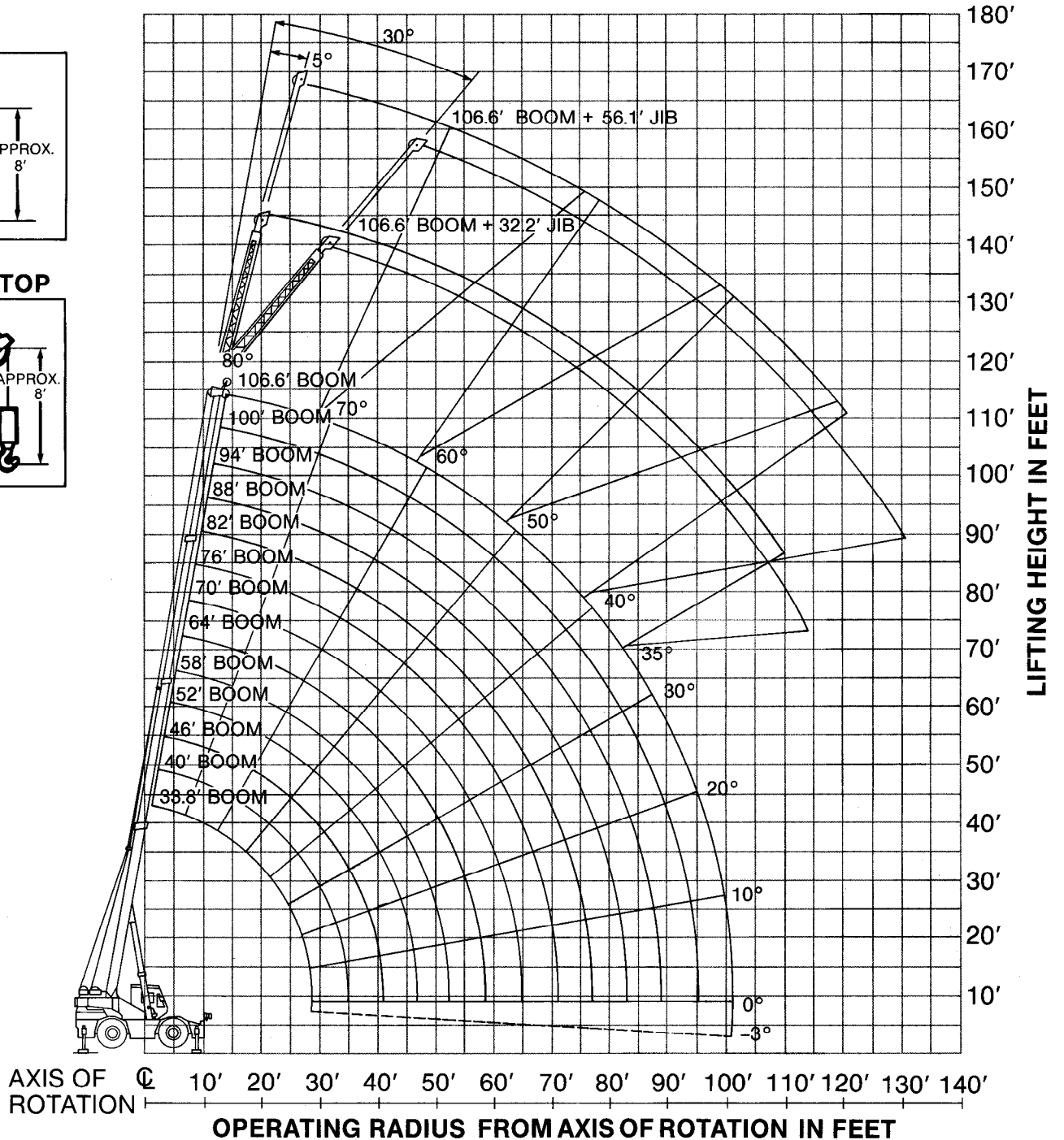

LIFTING HEIGHT IN FEET

AXIS OF ROTATION 10' 20' 30' 40' 50' 60' 70' 80' 90' 100' 110' 120' 130' 140'
OPERATING RADIUS FROM AXIS OF ROTATION IN FEET

Lifting Capacities

Working Radius (Feet)	360° Rotation																	
	Boom Length in Feet																	
	33.8'	40'	46'	52'	58'	64'	70'	76'	82'	33.8'	40'	46'	52'	58'	64'	70'	76'	82'
10'	64°	90,000	69°	81,200	72°	77,100	74°	68,000	76°	67,400								
12'	60°	79,300	66°	78,000	69°	76,500	72°	64,700	74°	62,300	76°	55,600	77°	47,300				
15'	55°	65,400	61°	65,400	65°	65,600	68°	59,700	71°	55,700	73°	49,800	75°	44,200	76°	40,300	77°	37,400
20'	43°	48,500	52°	48,500	58°	48,600	62°	48,000	65°	47,400	68°	42,000	70°	37,000	72°	33,500	74°	32,000
25'	27°	37,400	42°	37,600	50°	37,900	55°	38,100	60°	38,500	63°	35,300	66°	31,900	68°	28,300	70°	26,500
30'			29°	29,800	41°	30,000	48°	30,200	54°	30,500	58°	29,500	61°	28,000	64°	24,400	66°	22,800
35'			3°	23,800	30°	24,400	40°	24,700	47°	24,900	52°	24,800	56°	24,900	59°	21,600	62°	19,600
40'					10°	20,400	30°	20,600	40°	20,800	46°	20,800	51°	20,800	55°	18,700	58°	17,300
45'							15°	17,300	31°	17,400	39°	17,400	45°	17,400	50°	15,800	54°	15,200
50'									18°	14,100	31°	14,100	39°	14,100	45°	13,500	49°	13,600
55'											20°	11,900	32°	11,900	39°	12,000	44°	12,300
60'													22°	9,900	32°	10,100	39°	10,100
65'															23°	8,200	32°	8,400
70'															5°	6,200	25°	6,800
75'																	3°	6,200
80'																		
85'																		
90'																		
95'																		
100'																		

NOTE: Before operating crane, refer to WARNING AND OPERATING INSTRUCTIONS for using the Working Condition Indicator.

Warning And Operating Instructions

GENERAL

- Total rated loads shown on the TOTAL RATED LOAD CHART apply only to the machine as originally manufactured and normally equipped by TADANO LTD. Modifications to the machine or use of optional equipment other than that specified can result in a reduction of capacity.
- Construction equipment can be dangerous if improperly operated or maintained. Operation and maintenance of this machine must be in compliance with the information in the operation, safety and maintenance manual supplied with machine. If this manual is missing, order replacement through the distributor.
- The operator and other personnel associated with this machine shall fully acquaint themselves with the latest applicable American National Standards Institute (ANSI) safety standards for cranes.

SET UP

- Total rated loads shown on the chart are the maximum allowable crane capacities and are based on the machine standing level on firm supporting surface under ideal job conditions. Depending on the nature of the supporting surface, it may be necessary to have structural supports under the outrigger floats or tires to spread the load to a larger bearing surface.
- For outrigger operation, outriggers shall be fully extended with tires free of supporting surface before operating crane.

OPERATION

- Total rated load with outrigger fully extended do not exceed 85% of the tipping loads as determined by SAE Crane Stability Test Code J-765.
- Total rated loads above bold lines in the chart are based on crane strength and those below, on its stability. They are based on actual load radius increased by boom deflection.
- Total rated loads include the weight of main hook block (1000 lbs. for 45 tons capacity), optional secondary hook block (580 lbs. for 22 tons capacity), auxiliary hook ball (330 lbs. for 5.5 tons capacity), sling and auxiliary lifting devices and their weights shall be subtracted from the listed capacities to obtain the load actually lifted.

- Total rated loads are based on freely suspended loads and make no allowance for such factors as the effect of wind, sudden stopping of loads, supporting surface conditions, inflation of tires, operating speeds, side loads, etc. Side pull on boom or jib is extremely dangerous.
- Total rated loads do not account for wind on lifted load or boom. Total rated loads and boom length shall be appropriately reduced, when wind velocity is above 20 mph (9m/sec).
- Total rated loads at load radius shall not be exceeded. Do not tip the crane to determine allowable loads.
- Do not operate at boom lengths beyond radii or boom angle where no capacities are shown. Crane may overturn without any load on the hook.
- When boom length is between values listed, refer to the total rated load of the next longer and next shorter booms for the same radius. The lesser of the two total rated loads shall be used.
- When making lifts at a load radius not shown, use the next longer radius to determine allowable capacity.
- Single line operation should not exceed 11000 lbs. (5000 kgs).
- Loaded boom angles are approximate. The boom angle before loading should be greater to account for deflection.
- When making lift on outriggers, telescoping boom sections must be extended equally at all times. If 2nd, 3rd and top boom sections do not telescope evenly, equalize their travels by using "TELESCOPING CORRECTION" switches, before lifting loads.
- The 33.8' feet (10.3 m) boom length capacities are based on boom fully retracted. If not fully retracted (less than 40.0 feet [12.2 m] boom length), use the total rated loads for the 40.0 feet (12.2 m) boom length.
- Extension or retraction of the boom with loads may be attempted within the limits of the TOTAL RATED LOAD CHART. The ability to telescope loads is limited by hydraulic pressure, boom angle, boom length, crane maintenance, etc.
- For lifting capacity of single top, reduce 1000 lbs. (450 kgs) from the total rated loads of relevant boom. Capacities of single top shall not exceed 11000 lbs. (5000 kgs) including main hook.

On Outriggers

Lifting Radius (Feet)	360° Rotation							
	Boom Length in Feet							
	∠°	88'	∠°	94'	∠°	100'	∠°	106.6'
10'								
12'								
15'								
20'	75°	31,000	76°	30,400	77°	28,600		
25'	72°	25,900	73°	25,400	75°	24,900	76°	23,900
30'	68°	22,000	70°	21,600	71°	21,100	73°	19,900
35'	64°	19,000	67°	18,500	68°	18,100	70°	17,200
40'	61°	16,400	63°	16,000	65°	15,700	67°	14,800
45'	57°	14,700	59°	14,300	62°	13,800	64°	13,000
50'	53°	13,100	56°	12,700	59°	12,300	61°	11,400
55'	49°	11,800	52°	11,300	55°	10,900	58°	10,000
60'	44°	10,400	48°	10,200	51°	9,800	54°	9,000
65'	39°	8,600	43°	8,900	47°	8,600	51°	7,900
70'	33°	7,100	39°	7,500	43°	7,500	47°	7,100
75'	25°	6,300	33°	6,200	39°	6,300	43°	6,200
80'	16°	5,000	27°	5,000	33°	5,200	39°	5,200
85'			18°	4,600	27°	4,600	34°	4,600
90'					19°	3,900	29°	3,800
95'					3°	3,300	21°	3,000
100'							12°	2,600

Boom Angle in Degrees	Boom Length in Feet			
	106.6' (32.5 m) Boom + 32.2' (9.8 m) Jib		106.6' (32.5 m) Boom + 56.1' (17.1 m) Jib	
	5° Tilt	30° Tilt	5° Tilt	30° Tilt
80°	11,000	5,500	6,100	2,300
75°	9,200	4,900	5,000	2,200
70°	7,000	4,400	4,100	1,900
65°	5,500	3,800	3,500	1,800
60°	4,500	3,300	2,800	1,700
55°	3,700	2,800	2,300	1,600
50°	3,200	2,600	1,900	1,400
45°	2,500	2,300	1,600	1,300
40°	1,600	1,500	1,200	1,200

NOTES

∠° = degrees.

Boom Angles are in degrees.

Standard number of part lines should be according to the following table.

Boom Length in Feet (meters)	33.8' to 46' (10.3 to 14.0)	46' to 64' (14.0 to 19.5)	64' to 106.6' (19.5 to 32.5)	Single Top Jib
No of part lines	8	6	4	1

The WORKING CONDITION INDICATOR stores the lifting capacity data based on the standard number parts of line listed in the chart.

For Lifting Capacities

- When erecting and stowing jib, be sure to retain it by hand or by other means to prevent its free movement.
- 6200 lbs. (2800 kgs) shall be subtracted from the total rated loads of main boom, when jib is attached to main boom head. Jib weight is 2200 lbs. (1000 kgs).
- Use Anti-Two Block (OVERWIND CUTOFF) disable switch when erecting and stowing the jib and stowing the hook block. While the switch is pushed, the hoist does not stop, even when overwind condition occurs.
- Stop swing operation immediately when SWING warning lamp lights and warning buzzer sounds. These warnings are emitted when swinging into area A (diagram 1) with boom angle below 9°. This condition would cause a collision between boom elevating cylinders and engine hood.

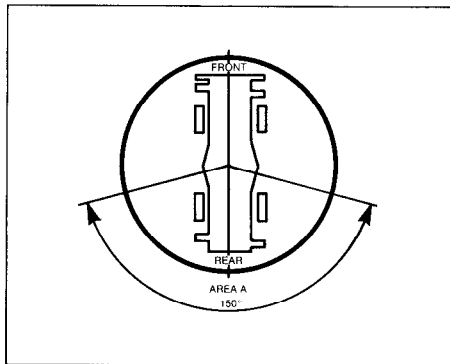

Diagram 1

- For boom lengths with 32.2' (9.8 m) Jib, the total rated loads are determined by loaded boom angle only in the column headed "106.6' (32.5 m) Boom + 32.2' (9.8 m) Jib". For boom lengths with 56.1' (17.1 m) Jib, the total rated loads are determined by loaded boom angle only in the column headed "106.6' (32.5 m) Boom + 56.1' (17.1 m) Jib". For angles not shown, use the next lower boom angle to determine allowable capacity.
- When lifting a load by using jib (auxiliary hoist) and boom (main hoist) simultaneously, do the following:
 - Set BOOM SELECT switch to position corresponding to actual operating conditions, "JIB—".
 - Before starting operation, make sure that the weight of load is within the total rated load for jib.

DEFINITIONS

- Load Radius:** Horizontal distance from a projection of the axis of rotation to supporting surface before loading to the center of the vertical hoist line or tackle with load applied.
- Loaded Boom Angle:** The angle between the boom base section and the horizontal, after lifting the total rated load at the load radius.
- Working Area:** Area measured in a circular arc about the centerline of rotation.
- Freely Suspended Load:** Load hanging free with no direct external force applied except by the hoist line.
- Side Load:** Horizontal side force applied to the lifted load either on the ground or in the air.

Lifting Capacities On Rubber

Working Radius in Feet	Stationary		Creep
	Over Front	360° Rotation	Over Front
10'	55,100 (a)	34,100 (a)	50,200 (a)
12'	49,300 (a)	31,300 (a)	45,300 (a)
15'	43,400 (a)	22,800 (a)	38,100 (a)
20'	32,700 (a)	14,400 (c)	28,100 (a)
25'	22,100 (b)	9,300 (e)	19,800 (b)
30'	16,800 (d)	6,300 (e)	16,200 (b)
35'	13,300 (e)	4,500 (e)	13,100 (d)
40'	10,500 (e)	3,300 (e)	10,500 (e)
45'	9,200 (e)	2,600 (e)	9,200 (e)
50'	6,900 (e)	1,700 (e)	6,900 (e)
55'	5,700 (e)		5,700 (e)
60'	4,800 (e)		4,800 (e)
65'	3,800 (e)		3,800 (e)
70'	3,300 (e)		3,300 (e)
75'	2,800 (e)		2,800 (e)

NOTE:
The WORKING CONDITION INDICATOR stores the lifting capacity data based on the standard number parts of line listed in the chart.

Max. permissible Boom Length in Feet
(Second Boom Section fully retracted)

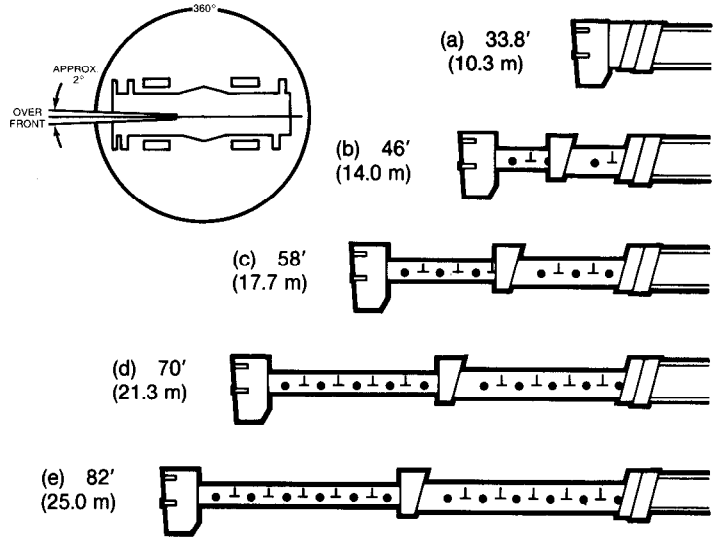

Warning And Operating Instructions For On Rubber Capacities

- Total rated loads on rubber are in pounds and do not exceed 75% of tipping loads as determined by test in accordance with SAE J-765.
- Total rated loads shown in the chart are based on condition that crane is set on firm level surface with axle oscillation lockout applied. Those above bold lines are based on tire capacity and those below, on crane stability. They are based on actual load radius increased by tire deformation and boom deflection.
- If the axle oscillation lockout cylinders contain air, the axle will not be locked completely and total rated loads may not be obtainable. Bleed the cylinders according to the operation, safety and maintenance manual.
- Total rated loads are based on proper tire inflation, capacity and condition. Damaged tires are hazardous to safe operation of crane.
- Tires shall be inflated to correct air pressure.

Tire	Air Pressure
21.00-25-24PR	85 psi (5.95 kgf/cm ²)
26.50-25-24PR	75 psi (5.25 kgf/cm ²)
29.50-25-22PR	60 psi (4.20 kgf/cm ²)

- Over front operation shall be performed within two degrees in front of chassis.
- When making lift on rubber, second boom section must be fully retracted. Third and top boom section must be extended equally. If not, equalize their extension by using "TELESCOPING CORRECTION" switches, before lifting loads.
- On rubber liftings with "jib" and "single top" are not permitted. Maximum permissible boom length is 82 feet (25.0 m).
- When making lift on rubber, set parking brake.
- For creep operation, boom must be centered over front of machine, swing lock engaged, and load restrained from swinging. Travel slowly and keep the lifting load as close to the ground as possible, and especially avoid any abrupt steering, accelerating or braking.
- Do not operate the crane while carrying the load.
- Creep is motion for crane not to travel more than 200 feet (60 m) in any 30 minute period and to travel at the speed of less than 1 mph (1.6 km/h).

Warning And Operating Instructions For Using The Working Condition Indicator

- When operating crane on outriggers:
 - Set P.T.O. switch to "ON".
 - Set OUTRIGGER SELECT switch to "FULL (On O/R)".
 - Set BOOM SELECT switch to position corresponding to actual operating conditions.
- When operating crane on rubber:
 - Set P.T.O. switch to "ON".
 - Set OUTRIGGER SELECT switch to position corresponding to actual operating conditions, in "On Rubber" range. However, pay attention to the following.
 - For Stationary Operation**
The front capacities are attainable only when OUTRIGGER SELECT switch is set to "FRONT" and "FRONT" indicator lamp is on. When boom is out of two degrees in front of chassis, "360°" indicator lamp is on and 360° capacities are effective.
 - For Creep Operation**
When OUTRIGGER SELECT switch is set to "Creep" and boom is in the straight forward position of chassis, "FRONT" indicator lamp flickers and creep capacities are attainable.
If boom is not in the straight forward position of chassis, never lift load.

When a load is lifted in the front position and then swung to the side area, be sure to set OUTRIGGER SELECT switch to "360°" in advance, and make sure that the value of WORKING CONDITION INDICATOR is below lifting capacity.

- During crane operation, make sure that the displays on front panel are in accordance with actual operating conditions.
- The displayed values of WORKING CONDITION INDICATOR are based on freely suspended loads and make no allowance for such factors as the effect of wind, sudden stopping of loads, supporting surface conditions, inflation of tires, operating speeds, side loads, etc.
For safe operation, it is recommended when extending and lowering boom or swinging, lifting loads shall be appropriately reduced.

Specifications subject to change without notice. The equipment described in this catalog may contain options. Standard equipment may vary depending upon regulations and requirements of destination country.

TADANO
HYDRAULIC CRANES

Subsidiary of **MITSUBISHI CORPORATION**
Machinery Distribution, Inc.
247 McCarty Drive
Houston, Texas 77029
Telephone: (713) 675-6000
Telex: 203 392 MDI UR