



TR-350XL-3

35 Ton Capacity (31.7 Metric Tons)

HYDRAULIC ROUGH TERRAIN CRANE

DIMENSIONS

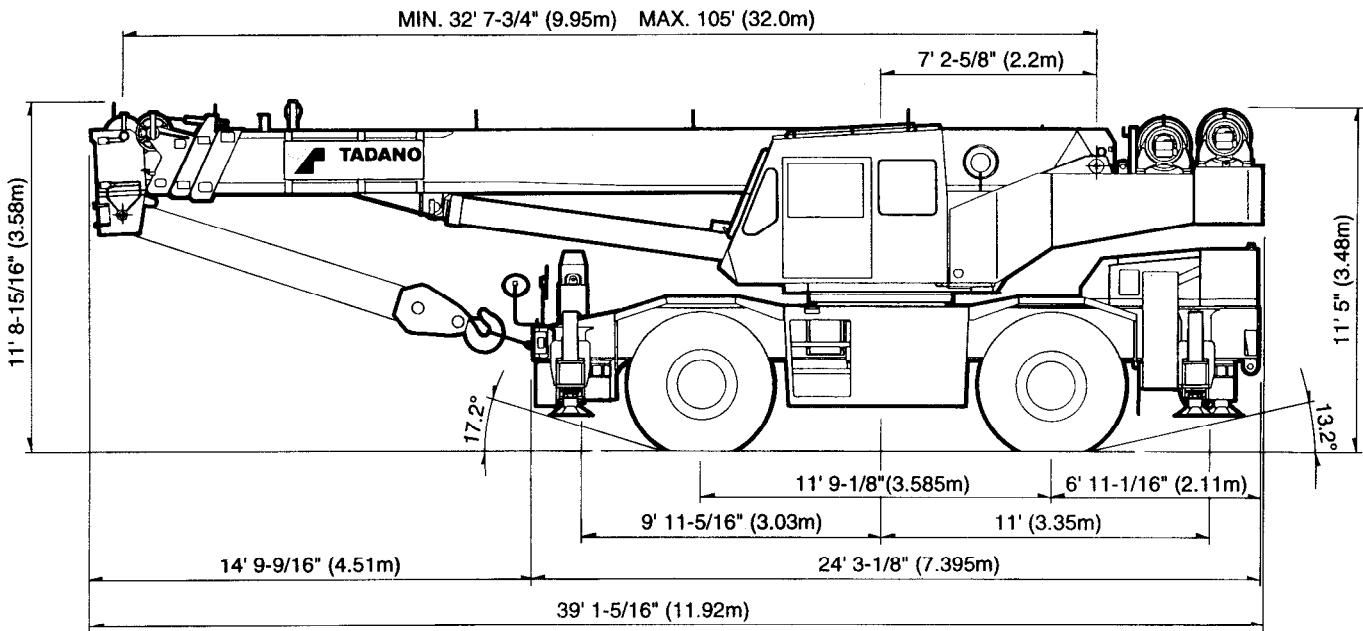

GENERAL DIMENSIONS (20.5×25 Tires)

	Feet	Meters
Turning radius:		
4 wheel steer	21'	6.4
2 wheel steer	36' 5"	11.1
Tail swing of counterweight	12' 9-9/16"	3.9

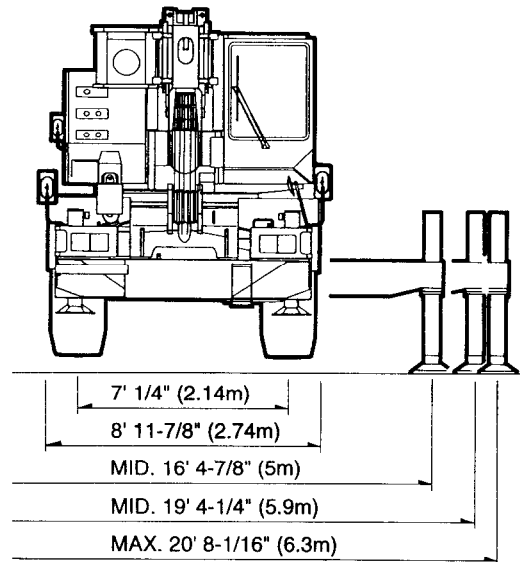

Specifications are subject to change without notice.

CRANE SPECIFICATIONS

BOOM

Four section full power partially synchronized telescoping boom, 32.6' ~ 105' (9.95m ~ 32m), of box construction with five sheaves, 12-5/8" (0.32m) root diameter, at boom head. The synchronization system consists of two telescope cylinders, an extension cable and retraction cable. Hydraulic cylinders fitted with holding valves. Two easily removable wire rope guards, rope dead end provided on right side of boom head. Boom telescope sections are supported by wear pads both vertically and horizontally.

BOOM ELEVATION - By a double acting hydraulic cylinder with holding valve. Elevation 0°~80°, combination controls for hand or foot operation. Boom angle indicator.

JIB - Box type top section telescopes from lattice type base section which stores alongside base boom section. 5°, 25° or 45° offset (tilt type). Single sheave, 13-7/8" (0.352m) root diameter, at jib head. Jib length is 23.6' (7.2m) or 42' (12.8m). Self stowing jib mounting pins.

AUXILIARY LIFTING SHEAVE (SINGLE TOP)

Single sheave, 12-5/8" (0.32m) root diameter. Mounted to main boom head for single line work (stowable).

ANTI-TWO BLOCK - Pendant type over-winding cut out device with audio-visual (FAILURE lamp/BUZZER) warning system.

SWING

Hydraulic axial piston motor driven through planetary swing speed reducer. Continuous 360° full circle swing on ball bearing turntable at 2.6rpm. Equipped with manually locked/released swing brake. A swing lock (360° positive swing lock) for pick and carry and travel modes, manually engaged in cab. Twin swing system: Free swing or lock swing controlled by selector switch on right hand console.

HOIST

MAIN HOIST - Variable speed type with grooved drum driven by hydraulic axial piston motor through planetary winch speed reducer. Power load lowering and raising. Equipped with automatic brake (Neutral brake) and counterbalance valve. Controlled independently of auxiliary hoist. Equipped with cable follower and drum rotation indicator.

DRUM - Grooved 12-5/8" (0.32m) root diameter × 19-1/16" (0.4845m) wide. Wire rope: 640' of 5/8" diameter rope (195m of 16mm). Drum capacity: 734' (223.6m) 6 layers. Maximum line pull (permissible): 9,755lbs. (4,425kg)*. Maximum line speed: 459FPM (140m/min).

AUXILIARY HOIST - Variable speed type with grooved drum driven by hydraulic axial piston motor through planetary winch speed reducer. Power load lowering and raising. Equipped with automatic brake (Neutral brake) and counterbalance valve. Controlled independently from main hoist. Equipped with cable follower and drum rotation indicator.

DRUM - Grooved 12-5/8" (0.32m) root diameter × 19-1/16" (0.4845m) wide. Wire rope: 328' of 5/8" diameter rope (100m of 16mm). Drum capacity: 734' (223.6m) 6 layers. Maximum line pull (permissible): 9,755lbs. (4,425kg)*. Maximum line speed: 459FPM (140m/min).

* Maximum permissible line pull may be affected by wire rope strength.

WIRE ROPE - Warrington seale wire, extra improved plow steel, pre-formed, independent wire rope core, right regular lay.
5/8"(16mm) 6×37 class

HOOK BLOCKS

1. 35 ton (31.7 metric ton) - 5 sheaves with swivel hook and safety latch, for 5/8" (16mm) wire rope.
2. 4.4 ton (4.0 metric ton) - Weighted hook with swivel and safety latch, for 5/8" (16mm) wire rope.

HYDRAULIC SYSTEM

PUMPS - Two variable piston pumps for crane functions. Tandem gear pump for steering, swing and optional equipment. Powered by carrier engine. Pump disconnect for crane is engaged/disengaged by rotary switch from operator's cab.

CONTROL VALVES - Multiple valves actuated by hand levers with integral pressure relief valves.

RESERVOIR - 139 gallon (527 lit.) capacity. External sight level gauge.

FILTRATION - 26 micron return filter, full flow with bypass protection, located inside of hydraulic reservoir. Accessible for easy replacement.

OIL COOLER - Air cooled fan type.

CAB AND CONTROLS

Both crane and drive operations can be performed from one cab mounted on rotating superstructure.

Left side, 1 man type, steel construction with sliding door access and tinted safety glass windows opening at side, rear and roof. Windshield glass window is shatter-resistant. Tilt-telescoping steering wheel. Adjustable control levers for swing, boom telescoping, boom hoist, auxiliary hoist and main hoist. Control levers for swing and auxiliary hoist can change neutral positions and tilt for easy access to cab. Engine throttle knob. Foot operated controls: boom hoist, boom telescoping, service brake and engine throttle.

Dash-mounted engine start/stop, monitor lamps, cigarette lighter, parking brake switch, steering mode select switch, pump engaged/ disengaged switch, swing brake switch, and telescoping correction switches.

Instruments - Torque converter oil temperature, engine water temperature, air pressure, fuel, speedometer, tachometer and hour meter. Torque converter oil pressure and hydraulic circuit pressure are monitored and displayed on the AML-L display panel.

Tadano electronic LOAD MOMENT INDICATOR system (AML-L) including:

- Control lever lockout function
- Working radius and/or boom angle and/or tip height preset function (warning only)
- Warning buzzer
- Boom angle/boom length/jib offset angle/working radius/rated loads/actual loads read out
- Ratio of actual load moment to rated load moment indication
- Working condition register switch
- External warning lamp

Tadano AML-L monitors outrigger extended length and automatically programs the corresponding "RATED LIFTING CAPACITIES" table.

CARRIER SPECIFICATIONS

TYPE - Rear engine, left hand steering, driving axle 2-way selected type by manual switch, 4x2 front drive, 4x4 front and rear drive.

FRAME - High tensile steel, all welded mono-box construction.

TRANSMISSION - Electronically controlled full automatic transmission. Torque converter driving full powershift with driving axle selector. 6 forward and 2 reverse speeds, constant mesh.

3 speeds - high range - 2 wheel drive; 4 wheel drive
3 speeds - low range - 4 wheel drive

MAX. TRAVEL SPEED - 29.3mph (47km/h)

MAX. TRAVEL SPEED - 29.3mph (47km/h)

AXLE - Front: Full floating type, steering and driving axle with planetary reduction. Rear: Full floating type, steering and driving axle with planetary reduction and non-spin differential.

STEERING - Hydraulic power steering controlled by steering wheel. Three steering modes available: 2 wheel front, 4 wheel coordinated and 4 wheel crab.

Operator's right hand console includes transmission gear selector, outrigger controls, sight level bubble, drive selector switch, free swing/lock swing selector switch, working light switch and ashtray. Swing lock lever and 4 way adjustable cloth seat with high back and seat belt. Roof window lock (closed) warning.

NOTE: Each crane motion speed is based on unladen conditions.

SUSPENSION - Front: Semi-elliptic leaf springs with hydraulic lockout device. Rear: Semi-elliptic leaf springs with hydraulic lockout device.

BRAKE SYSTEMS - Service: Air over hydraulic disc brakes on all 4 wheels. Parking/Emergency: Spring applied-air released brake acting on input shaft of front axle. Auxiliary: Electro-pneumatic operated exhaust brake.

TIRES - Standard 20.5-25-24PR (OR)

OUTRIGGERS - Four hydraulic, beam and jack outriggers. Vertical jack cylinders equipped with integral holding valve. Each outrigger beam and jack is controlled independently from cab. Beams extend to 20' 8-1/16" (6.3m) center-line and retract to within 8' 6-3/8" (2.6m) overall width with floats. Outrigger jack floats are attached thus eliminating the need of manually attaching and detaching them. Controls and sight bubble located in upper structure cab. Three outrigger extension lengths are provided with corresponding "RATED LIFTING CAPACITIES" for crane duty in confined areas.

Mid. extension 16' 4-7/8" center to center

Mid. extension 19' 4-5/16" center to center

Max. extension 20' 8-1/16" center to center

EN

Model	Mitsubishi 6D16-TLEA
Type	Direct injection diesel
No. of cylinders	6
Combustion	4 cycle, turbo charged and after cooled
Bore×stroke, in. (mm)	4.646×4.528 (118×115)
Displacement, cu. in (liters)	460 (7.545)
Air inlet heater	24 volt preheat
Air cleaner	Dry type, replaceable element
Oil filter	Full flow with replaceable element
Fuel filter	Full flow with replaceable element
Fuel tank, gal. (liters)	79.2 (300), right side of carrier
Cooling	Liquid pressurized, recirculating bypass

Radiator	Fin and tube core, thermostat controlled
Fan, in. (mm)	Suction type, 6-blade, 23.6 (600) dia.
Starting	24 volt
Charging	24 volt system, negative ground
Battery	2-120 amp. hour
Compressor, air, CFM (ℓ/min)	10.6 CFM (301) at 2,000 rpm
Horsepower (kw)	Gross 247 (184) at 2,800 rpm
Torque, max. ft-lb (kgm)	521 (72) at 1,400 rpm
Capacity, gal. (liters)	
Cooling water	3.4 (13)
Lubrication	3.7~4.2 (14~16)
Fuel	79.2 (300)

STANDARD EQUIPMENT

- Four section full power partially synchronized boom 32.6'~105' (9.95m~32m)
- Two stage stowable telescoping jib 23.6' (7.2m) or 42' (12.8m) with 5°, 25° or 45° pinned offset (tilt type) with self storing pins
- Auxiliary lifting sheave (single top) stowable
- Boom hoist foot control
- Boom telescoping foot control
- Boom angle indicator
- Variable speed main hoist with grooved drum, cable follower and 640' of 5/8" cable
- Variable speed auxiliary hoist with grooved drum, cable follower and 328' of 5/8" cable
- Drum rotation indicator (thumper type) main and auxiliary hoist
- Tadano twin swing system
- 360° positive swing lock
- Mitsubishi 6D16-TLEA turbo charged after cooled engine (247HP) with exhaust brake
- 4 × 4 × 4 drive
- 20.5-25-24PR (OR) tires
- Disc brake
- Hydraulic lockout suspension system
- Independently controlled outriggers
- Three outrigger extension positions
- Self-storing outrigger pads
- Electronic controlled automatic transmission driven by torque converter
- Engine over-run alarm
- Complete highway light package
- Anti two block device (overwind cutout)
- Electronic crane monitoring system
- Outrigger extended position detector
- Tadano electronic load moment indicator system (AML-L) including:
 - Control lever lockout function
 - Working radius and/or boom angle and/or tip height preset function (warning only)
 - Warning buzzer
 - Boom angle/boom length/jib offset angle/working radius/rated loads/actual loads read out
 - Ratio of actual load moment to rated load moment indication
 - Working condition register switch
 - External warning lamp
- Front windshield wiper and washer

- Roof window wiper and washer
- Roof window lock warning
- Tinted safety glass
- Rear view mirrors (right and left side)
- 4 way adjustable cloth seat with high back and seat belt
- Tilt-telescoping steering wheel
- Neutral position adjustable control lever (swing and auxiliary hoist)
- Cigarette lighter
- Cab floor mat
- Electric fan in cab
- Back-up alarm
- Low oil pressure/high water temperature warning device (visual)
- Rear steer centering light
- Fenders
- Air cleaner dust indicator
- Towing hooks - front and rear
- Lifting eyes
- Tool storage compartment
- Full instrumentation package
- Pump disconnect in operator's cab
- Air dryer
- Hydraulic oil cooler
- Non-spin rear differential
- Water separator with filter
- Flood lights and work lights
- Tire inflation kit
- Outrigger hose protection
- 24 volt electric system
- 35 ton (31.7 metric ton) 5 sheave hook block
- 4.4 ton (4.0 metric ton) hook ball and swivel
- Hook block tie down (front bumper)
- Weighted hook storage compartment

OPTIONAL EQUIPMENT

- Fire extinguisher
- Air conditioning including hydraulic oil cab heater/defroster with dehumidification function and cab cooler/ defroster
- Propane cab heater (less tank)

HOISTING SPECIFICATIONS

LINE SPEEDS AND PULLS

Layer	Speed	Main or auxiliary hoist – 12-5/8" (0.32m) drum					
		Line speeds ²		Line pulls			
		F.P.M	m/min	Available ¹		Permissible ⁴	
				Lbs.	kgf	Lbs.	kgf
1st	High	311	95	13,170	5,974	10,525	4,774
2nd	High	340	104	12,024	5,454	9,610	4,359
3rd	High	370	113	11,063	5,018	8,841	4,010
4th	High	399	122	10,243	4,646	8,186	3,713
5th	High	429	131	9,537	4,326	7,621	3,457
6th ³	High	459	140	8,922	4,047	7,130	3,234

¹ Developed by machinery with first layer of wire rope, but not based on rope strength or other limitation in machinery or equipment.

² Line speeds based only on hook block, not loaded.

³ Sixth layer of wire rope is not recommended for hoisting operations.

⁴ Permissible line pull may be affected by wire rope strength

DRUM WIRE ROPE CAPACITIES

Wire rope layer	Main and auxiliary drum grooved lagging			
	5/8" (16mm) wire rope			
	Rope per layer		Total wire rope	
	Feet	Meters	Feet	Meters
1	99	30.1	99	30.1
2	108	32.9	207	63.0
3	117	35.8	324	98.8
4	127	38.7	451	137.5
5	136	41.6	588	179.1
6	146	44.5	734	223.6

DRUM DIMENSIONS

	Inch	mm
Root diameter	12-5/8"	320
Length	19-1/16"	484.5
Flange diameter	20-7/8"	530

TR-350XL-3 WORKING RANGE CHART

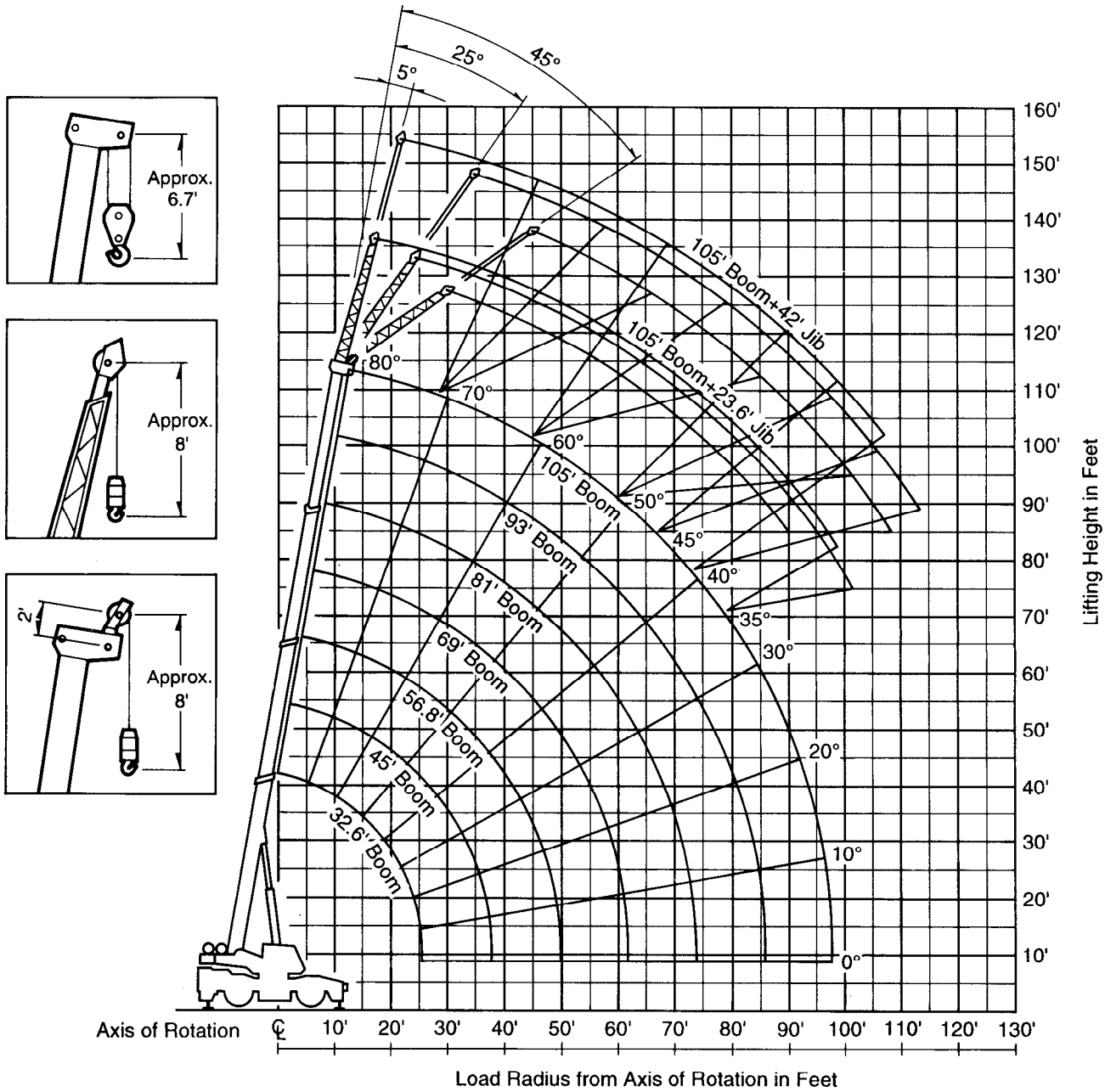

NOTE: Boom and jib geometry shown are for unloaded condition and machine standing level on firm supporting surface. Boom deflection and subsequent radius and boom angle change must be accounted for when applying load to hook.

TR350XL-3 RATED LIFTING CAPACITIES (IN POUNDS)

		ON OUTRIGGERS FULLY EXTENDED 360° ROTATION						ON OUTRIGGERS MID. EXTENDED 19' 4 1/4" (5.9m) SPREAD 360° ROTATION						
A B	32.6'	45'	56.8'	69'	81'	93'	105'	32.6'	45'	56.8'	69'	81'	93'	105'
	(9.95m)	(13.7m)	(17.3m)	(21.0m)	(24.7m)	(28.3m)	(32.0m)	(9.95m)	(13.7m)	(17.3m)	(21.0m)	(24.7m)	(28.3m)	(32.0m)
10'	70,000	60,000	46,000	37,600				70,000	60,000	46,000	37,600			
12'	56,500	52,000	46,000	37,600	31,800			56,500	52,000	46,000	37,600	31,800		
15'	46,500	45,300	42,500	37,600	31,800	22,400		46,500	45,300	42,500	37,600	31,800	22,400	
20'	36,000	36,000	35,000	30,800	29,200	22,400	15,850	36,000	36,000	35,000	30,800	29,200	22,400	15,850
25'	26,500	28,400	28,400	26,300	24,400	22,400	15,850	25,300	25,900	25,700	26,300	24,400	22,400	15,850
30'		21,700	21,200	22,300	20,700	18,900	15,850		18,000	17,900	19,000	19,500	18,900	15,850
35'		16,000	15,600	17,000	17,400	16,400	14,000		12,800	12,800	13,900	14,500	15,400	14,000
40'			11,700	13,000	13,700	14,100	12,400			9,400	10,700	11,300	12,100	12,400
45'			8,900	10,200	10,700	11,500	11,100			7,000	8,300	8,700	9,500	9,800
50'				8,000	8,500	9,200	9,700				6,400	6,800	7,500	7,900
55'				6,500	6,900	7,500	7,950				4,900	5,500	6,000	6,300
60'				5,200	5,500	6,100	6,500				3,800	4,300	4,700	5,100
65'					4,500	5,000	5,350					3,400	3,900	4,100
70'					3,600	4,100	4,400					2,700	3,000	3,300
75'						3,300	3,600						2,400	2,600
80'						2,600	2,850						1,900	2,000
85'						2,100	2,350							1,500
90'							1,870							
95'							1,350							
C	0°						0°						23°	

A: Boom Length in Feet B: Load Radius in Feet C: Minimum boom angle for indicated length (no load)

		ON OUTRIGGERS FULLY EXTENDED 360° ROTATION						ON OUTRIGGERS MID. EXTENDED 19' 4 1/4" (5.9m) SPREAD 360° ROTATION																
Boom Angle in Degree	Boom Length in Feet												Boom Length in Feet											
	105' (32.0m) Boom+23.6' (7.2m) Jib						105' (32.0m) Boom+42' (12.8m) Jib						105' (32.0m) Boom+23.6' (7.2m) Jib						105' (32.0m) Boom+42' (12.8m) Jib					
	5° offset		25° offset		45° offset		5° offset		25° offset		45° offset		5° offset		25° offset		45° offset		5° offset		25° offset		45° offset	
	R	W	R	W	R	W	R	W	R	W	R	W	R	W	R	W	R	W	R	W	R	W	R	W
80°	19.7	6,600	26.4	4,400	31.9	3,300	26.0	4,400	38.3	2,200	46.3	1,500	19.7	6,600	26.4	4,400	31.9	3,300	26.0	4,400	38.3	2,200	46.3	1,500
75°	31.6	6,600	37.8	4,400	42.6	3,300	39.8	4,400	51.2	2,200	57.9	1,500	31.6	6,600	37.8	4,400	42.6	3,300	39.8	4,400	51.2	2,200	57.9	1,500
70°	43.2	6,500	48.6	4,400	52.7	3,300	52.7	3,700	63.2	2,200	68.9	1,500	43.2	6,500	48.6	4,400	52.7	3,300	52.7	3,700	63.2	2,200	68.9	1,500
65°	53.7	5,200	58.9	3,900	62.4	3,300	64.8	3,150	74.5	2,000	79.0	1,500	53.7	5,200	58.9	3,900	62.4	3,300	64.8	3,150	74.5	2,000	79.0	1,500
60°	63.6	4,300	68.4	3,400	71.3	3,050	76.1	2,700	85.2	1,900	88.7	1,450	63.6	4,300	68.4	3,400	71.3	3,050	76.1	2,700	85.2	1,900	88.7	1,450
55°	72.8	3,650	77.4	3,000	79.6	2,750	86.6	2,300	94.9	1,750	98.0	1,400	72.6	3,000	77.2	2,700	79.4	2,450	86.6	2,300	94.9	1,750	98.0	1,400
50°	81.3	2,700	85.5	2,700	87.1	2,500	96.8	2,000	104.0	1,600	105.0	1,350	81.0	1,800	85.0	1,650	86.7	1,600	96.1	1,400	104.0	1,350	105.0	1,100
45°	89.1	2,000	92.8	1,900	93.8	1,850	105.0	1,550	112.0	1,450	112.0	1,300	88.7	900	92.3	850	93.2	850						
40°	96.2	1,300	99.3	1,250			113.0	1,050	119.0	1,000														
35°	103.0	850	105.0	800																				

R: Load Radius in Feet W: Rated Lifting Capacity

ON OUTRIGGERS MID. EXTENDED 16' 4 7/8" (5.0m) SPREAD							360° ROTATION	
32.6' (9.95m)	45' (13.7m)	56.8' (17.3m)	69' (21.0m)	81' (24.7m)	93' (28.3m)	105' (32.0m)	A	B
70,000	60,000	46,000	37,600				10'	
66,500	52,000	46,000	37,600	31,800			12'	
66,500	45,300	42,500	37,600	31,800	22,400		15'	
61,200	30,400	30,000	30,800	29,200	22,400	15,850	20'	
59,800	19,500	19,400	20,700	21,300	22,400	15,850	25'	
	13,600	13,400	14,500	15,100	15,800	15,850	30'	
	9,700	9,500	10,800	11,100	11,900	12,100	35'	
		6,900	7,800	8,400	9,000	9,400	40'	
		4,900	5,800	6,400	6,900	7,300	45'	
			4,400	5,000	5,300	5,700	50'	
			3,200	3,600	4,200	4,500	55'	
			2,300	2,700	3,200	3,600	60'	
				2,100	2,400	2,700	65'	
					1,700	2,000	70'	
						1,500	75'	
							80'	
							85'	
							90'	
							95'	
								C
							0°	
							26°	
							35°	

Boom length in feet

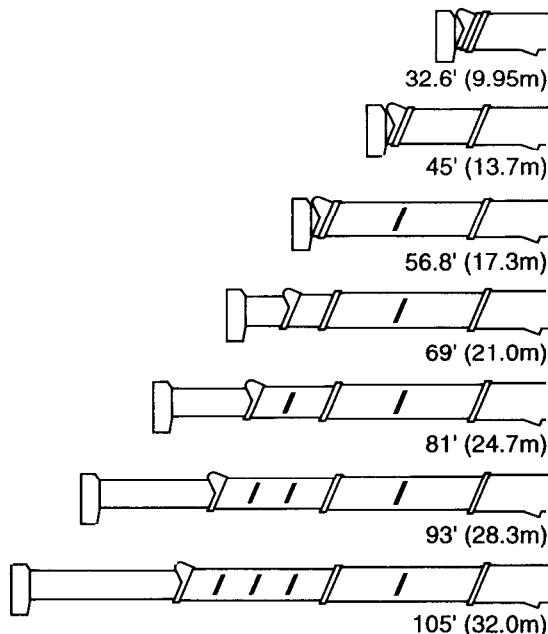

ON OUTRIGGERS MID. EXTENDED 16' 4 7/8" (5.0m) SPREAD											360° ROTATION	
Boom Length in Feet											Boom Angle in Degree	
105' (32.0m) Boom+23.6' (7.2m) Jib					105' (32.0m) Boom+42' (12.8m) Jib							
25° offset		45° offset		5° offset		25° offset		45° offset				
W	R	W	R	W	R	W	R	W	R	W		
27.7	6,600	26.4	4,400	31.9	3,300	26.0	4,400	38.3	2,200	46.3	1,500	80°
26.6	6,600	37.8	4,400	42.6	3,300	39.8	4,400	51.2	2,200	57.9	1,500	75°
25.2	6,500	48.6	4,400	52.7	3,300	52.7	3,700	63.2	2,200	68.9	1,500	70°
24.3	4,600	58.9	3,900	62.4	3,300	64.8	3,150	74.5	2,000	79.0	1,500	65°
23.0	2,900	68.0	2,550	71.1	2,400	75.6	2,300	85.2	1,900	88.7	1,450	60°
21.9	1,600	76.8	1,450	79.2	1,400	85.9	1,300	94.3	1,050	97.0	1,000	55°
20.5	850											50°
												45°
												40°
												35°

NOTE: Load radiuses for jib operation are given for reference with the boom fully extended to 105' (32m)

3,300 lbs. (1,500 kg) shall be subtracted from the rated lifting capacities of main boom, when jib is attached to main boom head.

Jib weight is 1,300 lbs. (590 kg)

Standard number of parts of line should be according to the following table.

Boom length in feet (meters)	32.6' to 45' (9.95 to 13.7)	45' to 56.8' (13.7 to 17.3)	56.8' to 81' (17.3 to 24.7)	81' to 105' (24.7 to 32.0)	Single top Jib
No. of part line	10	8	6	4	1

The lifting capacity data stored in the LOAD MOMENT INDICATOR (AML-L) is based on the standard number of parts of line listed in the chart.

Maximum lifting capacity is restricted by the number of parts of line of LOAD MOMENT INDICATOR (AML-L).

WARNING AND OPERATING INSTRUCTIONS FOR LIFTING CAPACITIES

GENERAL

1. RATED LIFTING CAPACITIES apply only to the machine as originally manufactured and normally equipped by TADANO LTD. Modifications to the machine or use of optional equipment other than that specified can result in a reduction of capacity.
2. Construction equipment can be hazardous if improperly operated or maintained. Operation and maintenance of this machine must be in compliance with the information in the operation, safety and maintenance manual supplied with machine.
3. The operator and other personnel associated with this machine shall fully acquaint themselves with the latest American National Standards Institute (ANSI) safety standards for cranes.

SET UP

1. Rated lifting capacities on the chart are the maximum allowable crane capacities and are based on the machine standing level on firm supporting surface under ideal job conditions. Depending on the nature of the supporting surface, it may be necessary to have structural supports under the outrigger floats or tires to spread the load to a larger bearing surface.
2. For outrigger operation, outriggers shall be properly extended with tires free of supporting surface before operating crane.

OPERATION

1. Rated lifting capacities have been tested to and meet minimum requirements of SAE J1063-Cantilevered Boom Crane Structures-Method of Test.
2. Rated lifting capacities do not exceed 85% of the tipping loads on outriggers fully extended as determined by SAE J765-Crane Stability Test Code.
Rated lifting capacities for partially extended outriggers are determined from the formula, Rated Lifting Capacities = $(\text{Tipping Load} - 0.1 \times \text{Tip Reaction}) / 1.25$.
3. Rated lifting capacities above bold lines in the chart are based on crane strength and those below, on its stability. They are based on actual load radius increased by boom deflection.
4. Rated lifting capacities include the weight of main hook block (770lbs. for 35 ton capacity), auxiliary hook block (220lbs. for 4.4 ton capacity), sling and auxiliary lifting devices and their weights shall be subtracted from the listed capacities to obtain the net load to be lifted.
5. Rated lifting capacities are based on freely suspended loads and make no allowance for such factors as the effect of wind, sudden stopping of loads, supporting surface conditions, inflation of tires, operating speeds, side loads, etc. Side pull on boom or jib is extremely dangerous.
6. Rated lifting capacities do not account for wind on lifted load or boom. Rated lifting capacities and boom length shall be appropriately reduced, when wind velocity is above 20mph (9m/sec.).
7. Rated lifting capacities at load radius shall not be exceeded. Do not tip the crane to determine allowable loads.
8. Do not operate at boom lengths, radii, or boom angle, where no capacities are shown. Crane may overturn without any load on the hook.

9. When boom length is between values listed, refer to the rated lifting capacities of the next longer and next shorter booms for the same radius. The lesser of the two rated lifting capacities shall be used.
10. When making lifts at a load radius not shown, use the next longer radius to determine allowable capacity.
11. Load per line should not exceed 7,000lbs. (3,200kg) for main winch and 6,610lbs. (3,000kg) for auxiliary winch.
12. Check the actual number of parts of line with LOAD MOMENT INDICATOR (AML-L) before operation. Maximum lifting capacity is restricted by the number of parts of line of LOAD MOMENT INDICATOR (AML-L). Limited capacity is as determined from the formula, Single line pull for main winch (7,000lbs.) \times number of parts of line.
13. The boom angle before loading should be greater to account for deflection.
14. The 32.6' (9.95m) boom length capacities are based on boom fully retracted. If not fully retracted [less than 45' (13.7m) boom length], use the rated lifting capacities for the 45' (13.7m) boom length.
15. Extension or retraction of the boom with loads may be attempted within the limits of the RATED LIFTING CAPACITIES. The ability to telescope loads is limited by hydraulic pressure, boom angle, boom length, crane maintenance, etc.
16. For lifting capacity of single top, reduce the rated lifting capacities of relevant boom by 750lbs. (340kg). Capacities of single top shall not exceed 6,610lbs. (3,000kg) including main hook.
17. When erecting and stowing jib, be sure to retain it by hand or by other means to prevent its free movement.
18. 3,300lbs. (1,500kg) shall be subtracted from the rated lifting capacities of the main boom, when jib is attached to main boom head. Jib weight is 1,300lbs. (590kg).
19. Use "OVERWIND CUTOFF" disable switch when erecting and stowing jib and stowing hook block. While the switch is pushed, the hoist does not stop, even when overwind condition occurs.
20. For boom length with 23.6' (7.2m) jib or 42' (12.8m), rated lifting capacities are determined by boom length and loaded boom angle. For angles not shown, use the next lower loaded boom angle to determine allowable capacity. When boom length is between values listed, refer to the rated lifting capacities of next longer boom for the same angle. However, as for the capacity of 32.6' (9.95m) boom and 45' (13.7m) boom is the same as the capacities of 56.8' (17.3m) boom.
21. When lifting a load by using jib (aux. winch) and boom (main winch) simultaneously, do the following:
 - Enter the operation status as jib operation, not as boom operation.
 - Before starting operation, make sure that weight of load is within rated lifting capacity for jib.

DEFINITIONS

1. Load Radius: Horizontal distance from a projection of the axis of rotation to supporting surface before loading to the center of the vertical hoist line or tackle with load applied.
2. Loaded Boom Angle: The angle between the boom base section and the horizontal, after lifting the rated lifting capacity at the load radius.
3. Working Area: Area measured in a circular arc about the centerline of rotation.
4. Freely Suspended Load: Load hanging free with no direct external force applied except by the hoist line.
5. Side Load: Horizontal side force applied to the lifted load either on the ground or in the air.

TR-350XL RATED LIFTING CAPACITIES (IN POUNDS)

TIRE: 20.5-25-24PR

ON RUBBER											
A B		Stationary					Creep				
		Over Front			360° Rotation		Over Front				
		Boom Length in Feet			Boom Length in Feet		Boom Length in Feet				
		32.6' (9.95m)	56.8' (17.3m)	81' (24.7m)	32.6' (9.95m)	56.8' (17.3m)	81' (24.7m)	32.6' (9.95m)	56.8' (17.3m)	81' (24.7m)	
10'		38,000			26,500			31,600			
12'		36,700	32,700	15,300	19,600	18,800		27,200	26,800	15,300	
15'		30,300	28,200	15,300	13,200	12,400	13,600	22,200	21,900	15,300	
20'		19,300	18,600	14,500	7,600	6,700	7,900	16,400	16,000	14,500	
25'		12,400	12,100	13,000	4,500	3,900	5,100	12,400	12,100	13,000	
30'			8,100	10,000		2,000	3,100		8,100	10,000	
35'			5,600	7,400			1,700		5,600	7,400	
40'			3,900	5,600					3,900	5,600	
45'			2,500	4,200					2,500	4,200	
50'				3,100						3,100	
55'				2,300						2,300	
60'				1,500						1,500	
65'				1,100						1,100	
C		0°		26°	0°		46°	58°	0°		26°

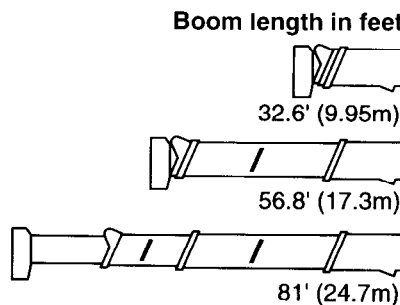
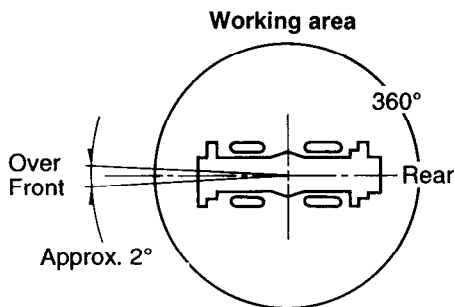

A: Boom Length in Feet (meters)

B: Load Radius in Feet

C: Minimum boom angle for indicated length (no load)

NOTE: Standard number of parts of line for on rubber operation should be according to the following table. The lifting capacity data stored in the LOAD MOMENT INDICATOR (AML-L) is based on the standard number of parts of line listed in the chart.

Boom length in feet (meters)	32.6' (9.95)	32.6' to 81' (9.95 to 24.7)	Single top
No. of part line	6	6 (4) *	1

*Stationary 360° Rotation requires 4 parts of line.

WARNING AND OPERATING INSTRUCTIONS FOR ON RUBBER CAPACITIES

- Rated lifting capacities on rubber are in pounds and do not exceed 75% of tipping loads as determined by SAE J765-Crane Stability Test Code.
- Rated lifting capacities shown in the chart are based on condition that crane is set on firm level surfaces with suspension lock applied. Those above bold lines are based on tire capacity and those below, on crane stability. They are based on actual load radius increased by tire deformation and boom deflection.
- Rated lifting capacities are based on proper tire inflation, capacity and condition. Damaged tires are hazardous to safe operation of crane.
- Tires shall be inflated to correct air pressure.

Tires	Air pressure
20.5-25-24PR	93 psi. (6.5kgf/cm ²)
- Over front operation shall be performed within two degrees in front of chassis.
- On rubber lifting with "jib" is not permitted. Maximum permissible boom length is 81ft. (24.7m).
- When making lift on rubber stationary, set parking brake.
- For creep operation, boom must be centered over front of machine, swing lock engaged, and load restrained from swinging. Travel slowly and keep the lifted load as close to the ground as possible, and especially avoid any abrupt steering, accelerating or braking.
- Do not operate the crane while carrying the load.
- Creep is motion for crane not to travel more than 200ft. (60m) in any 30 minute period and to travel at the speed of less than 1mph (1.6km/h).
- For creep operation, set drive select switch to "4-WHEEL (Lo)" and set gear shift lever to "1".

WARNING AND OPERATING INSTRUCTIONS FOR USING THE LOAD MOMENT INDICATOR (AML-L)

1. When operating crane on outriggers:
 - Set P.T.O. switch to "ON" .
 - Press the outrigger mode select key to register for the outrigger operation. The outrigger mode indicative symbol changes from flickering to lighting.
 - Press the boom mode select key to register the boom mode. Each time the boom mode select key is pressed, the mode changes. Select the status that corresponds to the actual state of the boom.
 - When erecting and stowing jib, select the status of jib set (jib state indicative symbol flicker).
 2. When operating crane on rubber:
 - Set P.T.O. switch to "ON" .
 - Press the on-tire mode select key. The outrigger mode indicative symbol will disappear as the on-tire mode indicative symbol comes on. Each time the on-tire mode select key is pressed, the mode changes. Select the creep operation, the on-tire mode indicative symbol flicker.
 - Press the boom mode select key to register the boom mode.
- However, pay attention to the following:
- (1) For stationary operation:
 - The front capacities are attainable only when the over front position symbol comes on. When the boom is more than 2 degrees from centered over front of chassis, 360° capacities are in effect.
 - When a load is lifted in the front position and then swung to the side area, make sure the value of the LOAD MOMENT INDICATOR (AML-L) is below the 360° lifting capacity.
 - (2) For creep operation:
 - The creep capacities are attainable only when boom is in the straight forward position of chassis and the over front position symbol is on. If boom is not in the straight forward position of chassis, never lift load.
3. A swing does not automatically stop even if the crane becomes overloaded.
 4. During crane operation, make sure that the displays on front panel are in accordance with actual operating conditions.
 5. The displayed values of LOAD MOMENT INDICATOR (AML-L) are based on freely suspended loads and make no allowance for such factors as the effect of wind, sudden stopping of loads, supporting surface conditions, inflation of tires, operating speed, side loads, etc. For safe operation, it is recommended when extending and lowering boom or swinging, lifting loads shall be appropriately reduced.
 6. LOAD MOMENT INDICATOR (AML-L) is intended as an aid to the operator. Under no condition should it be relied upon to replace use of capacity charts and operating instructions. Sole reliance upon LOAD MOMENT INDICATOR (AML-L) aids in place of good operating practice can cause an accident. The operator must exercise caution to assure safety.

TR-350XL-3 Axle weight distribution chart

	Pounds			Kilograms		
	GVW	Front	Rear	GVW	Front	Rear
Basic standard machine includes: 32.6'~105' (9.95~32m) 4-section boom 23.6', 42' (7.2m, 12.8m) 2-stage jib Auxiliary lifting sheave (Single top) Main hoist with 640 ft. (195m) of 5/8" (16mm) diameter wire rope Aux. hoist with 328 ft. (100m) of 5/8" (16mm) diameter wire rope 35 ton (31.8 metric ton) 5 sheaves hook block 4.4 ton (4 metric ton) hook ball	61,520	33,542	27,978	27,900	15,212	12,688
Add: Air Conditioning	+250	+105	+145	+114	+48	+66
Remove: 23.6', 42' (7.2m, 12.8m) 2-stage jib	-1,280	-2,280	+1,000	-580	-1,036	+456